

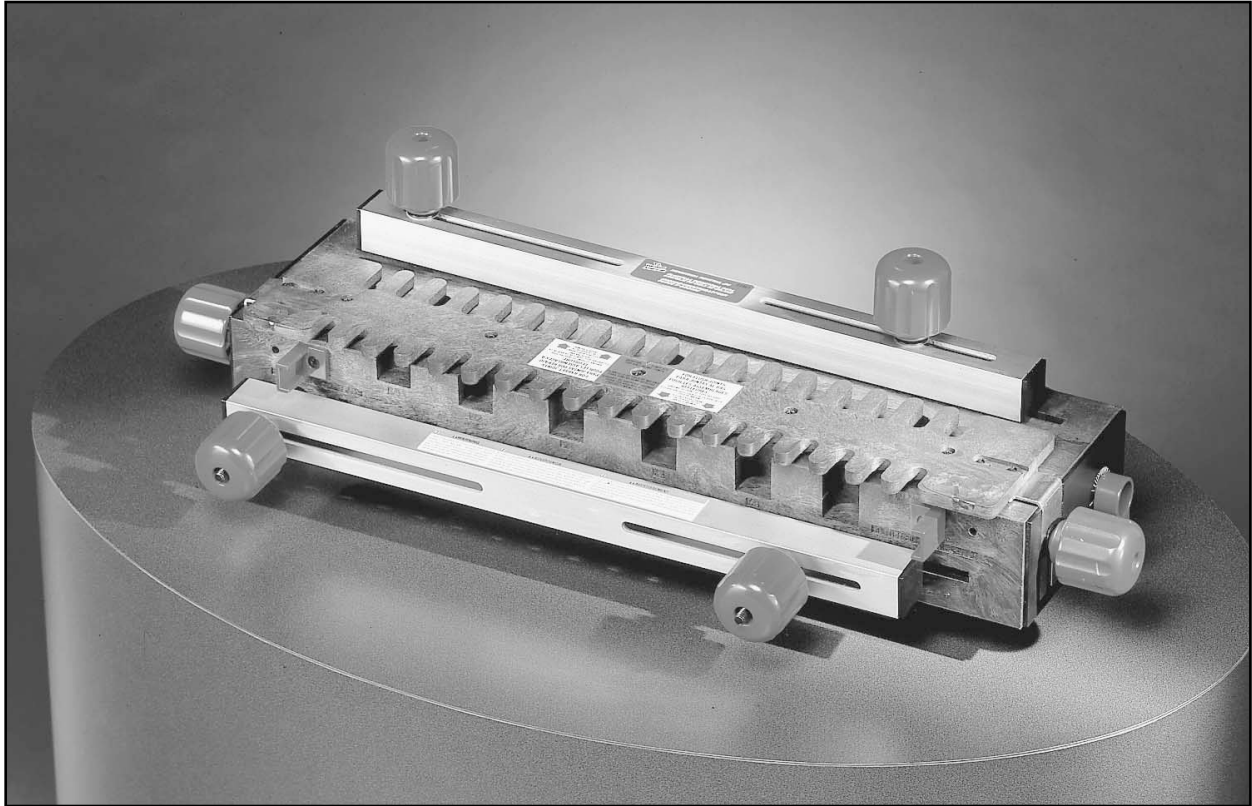

INDUSTRIAL DOVETAIL JIG



IMPORTANT: The following router bits are required for use with this jig.

- VA #22437, or MAGNA #M91016, 1/4" Straight Router Bit, and VA #22501, or MAGNA #M91114, 9/16" Dovetail Router Bit which are used for THROUGH or OPEN JOINTS.
- VA #22500, or MAGNA #M91113, 1/2" Dovetail Router Bit, which is used for all HALF BLIND JOINTS.

MODEL# 23461

WARNING:

Before operating product, read this manual and follow all its Safety and Operating Instructions.

USA

SAFETY

ASSEMBLY

INSTALLATION





OPERATION

PARTS LIST

TABLE OF CONTENTS

General Safety Instructions for Power Tools	3
Additional Safety Instructions for Industrial Dovetail Jig	4
Introduction	5
Unpacking and Checking Contents	5
Assembly	6
Assembly of the Right Side Template Support to the Dovetail Base	6
Assembly of the Top Clamping Bar to the Dovetail Base.....	7
Assembly of the Front Clamping Bar to the Dovetail Base	9
Assembly of the Cam Handles and Pivot Shaft to the Dovetail Base	10
Assembly of the Front Stop Blocks to the Dovetail Base	13
Assembly of the Top Stop Blocks to the Dovetail Base	14
Assembly of the Clamping Knobs to the Dovetail Base.....	14
Assembly of the Templates	15
Alignment of the Templates	16
Assembly of the Adapter Plate to the Router.....	18
Assembly of the Guide Bushing to the Router	21
Installation	22
Operation	24
Styles of Dovetail Joints	24
Half Blind Flush Joint	24
Half Blind Flush Offset Joint.....	25
Half Blind Rabbeted Joint	25
Open or Through Joint	26
Adjusting the Depth-of-Cut of the Router Bit.....	26
Clamping the Workpieces to the Dovetail Base	28
Making Drawers with Half Blind Flush Joints	29
Making Drawers with Half Blind Flush Offset Joints.....	35
Making Drawers with Half Blind Rabbeted Joints	35
Making Projects with Open (Through) Joints	37
Parts List	47

SAFETY GUIDELINES – DEFINITIONS

<p>This manual contains information that is important for you to know and understand. This information relates to protecting YOUR SAFETY and PREVENTING EQUIPMENT PROBLEMS. To help you recognize this information, we use the symbols to the right. Please read the manual and pay attention to these sections.</p>	 URGENT SAFETY INFORMATION - A HAZARD THAT WILL CAUSE SERIOUS INJURY OR LOSS OF LIFE	 INFORMATION FOR PREVENTING DAMAGE TO EQUIPMENT
	 IMPORTANT SAFETY INFORMATION - A HAZARD THAT <i>MIGHT</i> CAUSE SERIOUS INJURY OR LOSS OF LIFE	 INFORMATION THAT YOU SHOULD PAY SPECIAL ATTENTION TO

GENERAL SAFETY INSTRUCTIONS FOR POWER TOOLS

 Failure to heed all safety and operating instructions and warnings regarding use of this product can result in serious bodily injury.

1. Know your power tool

Read the owner's manual carefully. Learn its application and limitations as well as the specific potential hazards peculiar to this tool.

2. Ground all tools (unless double insulated)

If tool is equipped with an approved three-conductor cord and a three-prong grounding type plug, it should be plugged into a three hole electrical receptacle. If adapter is used to accommodate a two-hole receptacle, the adapter wire must be attached

to a known ground (usually the screw securing receptacle cover plate). Never remove third prong. Never connect green ground wire to a terminal.

3. Keep guards in place

Maintain in working order, and in proper adjustment and alignment.

4. Remove adjusting keys and wrenches

Form a habit of checking to see that keys and adjusting wrenches are removed from tool before turning it ON.

5. Keep work area clean

Cluttered areas and benches invite accidents. Floor must not be slippery due to wax or sawdust.

6. Avoid dangerous environment

Do not use power tools in damp or wet locations or expose them to rain. Keep work area well lighted. Provide adequate surrounding work space.

7. Keep children away

All visitors should be kept a **safe** distance from work area.

8. Make workshop child-proof

Use padlocks, master switches, or remove starter keys.

9. Do not force tools

Do not force tool or attachment to do a job it was not designed to perform.

10. Use the right tool

They will do the job better and safer at the rate for which they were designed.

11. Wear correct apparel

Do not wear loose clothing, gloves, neckties or jewelry (rings, wristwatches) that may get caught in moving parts. Non-slip footwear is recommended. Wear protective hair covering to contain long hair. Roll long sleeves above the elbow.

12. Use safety goggles (Head Protection)

Wear safety goggles (must comply with ANSI Standard Z87.1) at all times. Also, use face or dust mask, if cutting operation is dusty, and ear protectors (plugs or muffs) during extended periods of operation.

13. Secure work

Use clamps or a vise to hold work when practical. It's safer than using your hands, and both hands are free to operate tool.

14. Do not overreach

Keep proper footing and balance at all times.

15. Maintain tools with care

Keep tools sharp and clean for best and safest performance. Follow instructions for lubricating and changing accessories.

16. Disconnect tools before servicing

Before servicing, when changing accessories such as blades, bits, cutters, etc.

17. Avoid accidental starting

Make sure switch is in OFF position before plugging in.

18. Use recommended accessories

Consult the owner's manual for recommended accessories and follow the instructions. The use of improper accessories may cause hazards.

19. Never stand on tool

Serious injury could occur if the tool is tipped or if the cutting tool is accidentally contacted. DO NOT store materials above or near the tool making it necessary to stand on the tool to reach them.

20. Check damaged parts

Before further use of the tool, any guard or other part that is damaged should be carefully checked to ensure that it will operate properly and perform its intended function. Check for alignment of moving parts, binding of moving parts, breakage of parts, mounting, and any other conditions that may affect its operation. A guard or any other part that is damaged should be properly repaired or replaced.

21. Direction of feed

Feed work into a blade or cutter AGAINST the direction of rotation of the blade or cutter only.

22. Never leave tool running unattended

Turn power OFF. DO NOT leave tool until it comes to a complete stop.

23. Keep hands away from cutting area

24. Store idle tools

When not in use, tools should be stored in dry, high or locked-up place – out of reach of children.

25. Do not abuse cord

Keep cord away from heat, oil and sharp edges.

26. Outdoor extension cords

When tool is used outdoors, use only extension cords suitable for use outdoors and so marked.

27. Never use in an explosive atmosphere

Normal sparking of the motor could ignite fumes, flammable liquids, or combustible items.

28. Drugs, alcohol, medication

DO NOT operate tool while under the influence of drugs, alcohol, or any medication.

Read and Understand this instruction book completely **BEFORE** using this product.

ADDITIONAL SAFETY INSTRUCTIONS FOR THE INDUSTRIAL DOVETAIL JIG

1. Always wear eye protection that complies with ANSI Standard Z87.1.
2. Noise levels vary widely. To avoid possible hearing damage, wear ear plugs or muffs when using the Dovetail Jig for hours at a time.
3. For dusty operations, wear a dust mask along with safety goggles.
4. Do not use this Dovetail Jig with router bits or guide bushings other than those specified for the cuts being made.
5. Follow the instructions in your Router Owner's Manual.
6. Vibrations caused by the router during use can cause fasteners to become loose. Before use and periodically during use, check all fasteners to make sure that they are all are tight and secure.
7. Do not use this product until all assembly installation steps have been completed, and you have read and understand all safety and operational instructions in this manual, and the Router Owners Manual.
8. Make sure that the router bit is properly positioned in the router so that it does not contact the guide bushing or the template when cutting.
9. The Dovetail Jig must be securely mounted to a workbench or other stable surface when in use. The front of the base should overhang the front of the

- workbench **by no more than 1/4"** to provide clearance when clamping workpieces to the Dovetail Jig.
10. Do not use the Dovetail Jig as a work surface. Doing so may cause damage to the Dovetail Jig, which can cause it to be unsafe to use. A workbench should be used for this purpose.
11. This product is designed to cut flat workpieces. **Do not cut or attempt to cut workpieces that are not flat or that are irregularly shaped.**
12. This product is to be used for cutting wood workpieces only. **Do not use this product to cut metal or any other non-wood material.**
13. This product has been designed to cut workpieces having thicknesses of 3/8" to 1". Do not use for workpieces of any other thicknesses.
14. Do not clamp any workpieces to the Dovetail Jig or make any adjustments to the Dovetail Jig unless the router has been turned off, the router bit is not turning, and the Router has been disconnected from the electrical outlet.
15. When setting "**the-depth-of-cut**" of the router bit, make sure that the workpiece is clamped to the Dovetail Jig in such a manner that **the router bit does not cut into the Dovetail base causing damage to it or possible serious injury to you.**

16. **⚠ WARNING** ALWAYS UNPLUG THE ROUTER FROM THE ELECTRICAL OUTLET BEFORE INSTALLING OR REMOVING ROUTER BITS FROM THE ROUTER AND WHEN ADJUSTING THE CUTTING DEPTH OF THE ROUTER BIT; OR WHEN INSTALLING OR CHANGING GUIDE BUSHINGS.

17. NEVER LIFT THE ROUTER UPWARDS WHEN THE ROUTER IS "ON", THE ROUTER BIT IS ROTATING, AND THE GUIDE BUSHING IS NEAR OR TOUCHING THE TEMPLATE, BECAUSE THIS WILL CAUSE THE ROUTER BIT TO CUT INTO THE TEMPLATE AND DAMAGE IT.

INTRODUCTION

- Your Vermont American Industrial Dovetail Jig is an accessory that is used with Routers allowing you to make drawers, chests, and similar items requiring dovetail joints. The joints are used to make the front, back, and sides of the workpiece.
- Your Industrial Dovetail Jig comes with two templates and two guide bushings for making half-blind and through or open joints.
- Your Industrial Dovetail Jig also comes with a universal router adapter plate that will permit the Industrial Dovetail Jig to be used with most popular routers.
- The Dovetail Jig will allow you to make 1" spaced flush, flush-offset, and 3/8" rabbeted half-blind dovetail joints.
- The Dovetail Jig will also allow you to make 1" spaced open, or through, dovetail joints.
- Workpieces up to 16" wide can be accommodated.
- Workpieces with thicknesses between 3/8" and 1" can be accommodated.
- The Dovetail Jig Base has six pockets molded into its front which are gauges to aid you setting the "depth-of-cut" for commonly used depths: 3/8", 1/2", 5/8", 3/4", 7/8", and 1".
- Vermont American router bits, #22501 and #22437, or Magna router bits, #M91113 and #M91016, WHICH MUST BE PURCHASED SEPARATELY, are required for making the THROUGH or OPEN joints.
- Vermont American router bit, #22500, or Magna router bit, #M91114, WHICH MUST BE PURCHASED SEPARATELY, is required for making the HALF-BLIND joints.
- Your Vermont American Industrial Dovetail Jig comes with two templates and two guide bushings. Each of the templates has a label, describing the joint that can be cut with it, along with set-up information, the router bit and the guide bushing required, and the the stop block setting for a particular joint.

UNPACKING AND CHECKING CONTENTS

Refer to Parts List on Page 47.

- In order to simplify handling and to minimize any damage that may occur during shipping, your Industrial Dovetail Jig is packaged assembled.
- Separate all loose parts from the packing materials and check each one with the illustrations and list of parts at the end of this manual to make sure that all loose parts are present before discarding any packaging material.

- **⚠ WARNING** If any parts are missing or cannot be accounted for, do not attempt to assemble, install, or use the Industrial Dovetail Jig until the missing parts have been obtained and the product has been assembled correctly.
- Contact customer service at 1-800-742-3869, ext. 8359 for missing or replacement parts.

IMPORTANT

ALTHOUGH YOUR INDUSTRIAL DOVETAIL JIG COMES ASSEMBLED, THE FOLLOWING **ASSEMBLY INSTRUCTIONS** ARE BEING INCLUDED FOR REFERENCE PURPOSES SHOULD IT BECOME NECESSARY FOR YOU TO DISASSEMBLE AND REASSEMBLE THE DOVETAIL JIG.

PROCEED TO THE SECTION **ALIGNMENT OF THE TEMPLATES** AND THEN CONTINUE WITH THE **SECTIONS FOLLOWING ALIGNMENT OF THE TEMPLATES**.

THE TEMPLATES MUST BE ALIGNED BEFORE ANY ROUTING IS TO TAKE PLACE.

ASSEMBLY INSTRUCTIONS

TOOLS REQUIRED

- A medium sized Phillips screwdriver
- A small or medium adjustable wrench

ASSEMBLY OF THE RIGHT SIDE TEMPLATE SUPPORT TO THE DOVETAIL BASE

1. Place the dovetail base topside down on a flat surface.
2. Insert one of the 5/16-18 x 2" long round head square

neck bolts into the slot in the right side of the base. (NOTE: The right side of the base is identified by the words **RIGHT SIDE** molded into it.)

3. Place a 11/32" I.D. x 7/8" O.D. washer onto the bolt as shown in Figure 1.

4. Thread a 5/16-18 hex nut onto the bolt, as shown, until it bottoms out against the washer.

5. Back off the nut from the washer between 1/4 and 1/2

FIGURE 1

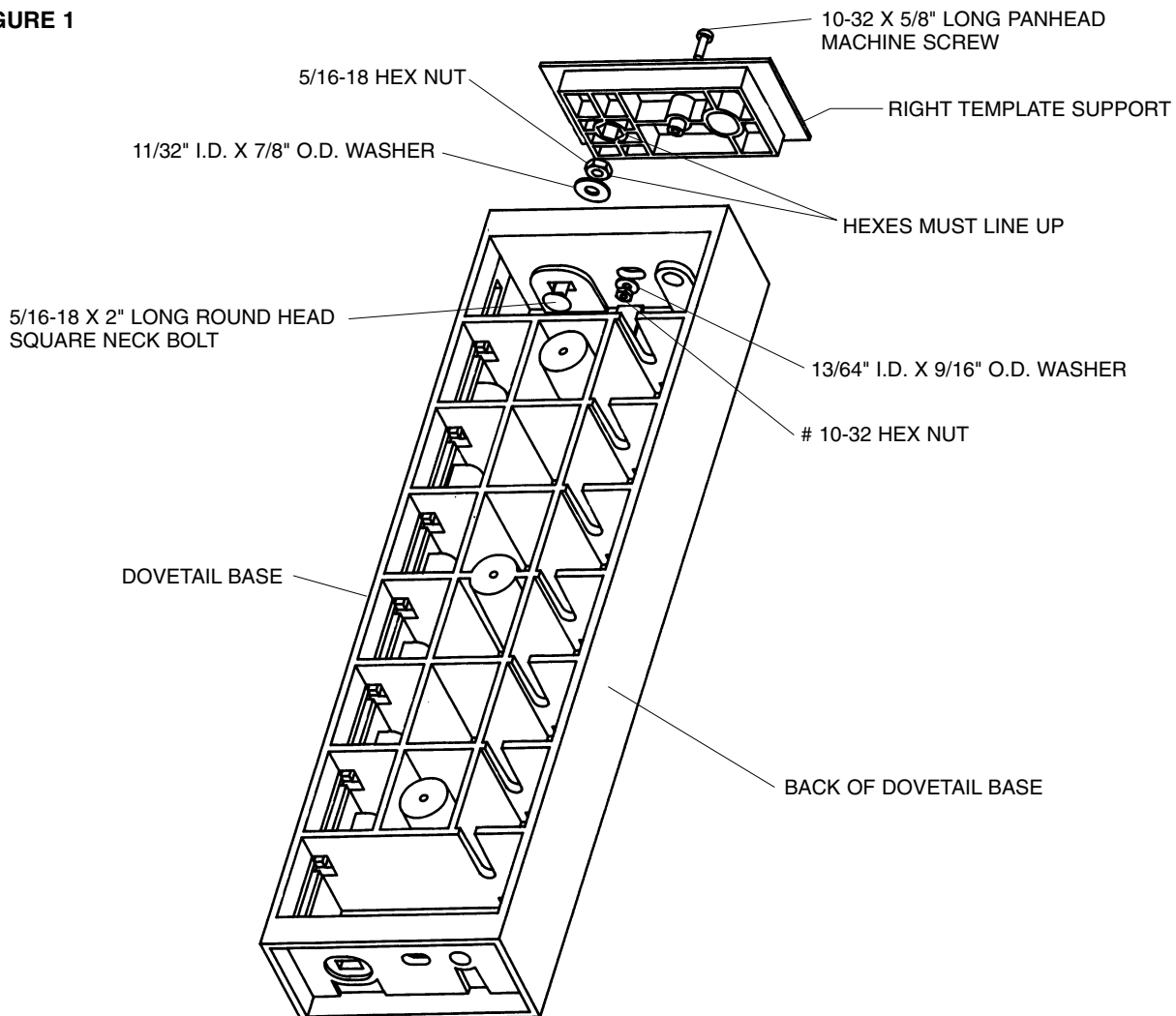

turns. Align the nut so that the corners of the nut are vertically lined up as shown. Note the alignment of the hex pocket in the template support. The bolt should be free to move side to side; if it does not, loosen the nut 1/3 turn or until the corners of the nut point up and down.

6. Assemble the right template support to the right side of the dovetail base so that the hex nut lines up and fits into the hex pocket in the right template support. (NOTE: The right template support has the words RIGHT SIDE molded into it for identification.)

7. Assemble a #10-32 x 5/8" long panhead machine screw, a 13/64" I.D. x 9/16" O.D. washer, and a #10-32 hex nut to

the base as shown to hold the template support in place. Securely tighten the nut and screw.

8. The template support should move freely front to back along the side of the base. If it does not, it means that the 5/16-18 hex nut is too tight on the bolt and should be loosened. To do this, remove the fasteners assembled in step 7, and remove the template support; repeat steps 4 through 7.

ASSEMBLE THE LEFT SIDE TEMPLATE SUPPORT TO THE DOVETAIL BASE THE SAME AS THE RIGHT SIDE TEMPLATE SUPPORT WAS ASSEMBLED.

ASSEMBLY OF THE TOP CLAMPING BAR TO THE DOVETAIL BASE

1. Assemble one of the bolt supports to both of the 5/16-18 X 3-1/2" long round head square neck bolts as shown in Figure 2.
2. Align the square on the bolt with the square hole in the bolt support. The bolt support is to "bottom-out" against the bolt as shown in Figure 3.
3. Assemble one of the springs to each of the nylon spring retainers by pushing the spring over the raised cylindrical portion of the spring retainer as shown in Figure 3A and Figure 3B.
4. Position the dovetail base on a flat smooth surface so the back of the base rests on the surface.

NOTE

ALTHOUGH BOTH ENDS OF THE DOVETAIL BASE ARE SHOWN ASSEMBLED IN THE FOLLOWING FIGURES, THE ACTUAL ASSEMBLY IS DONE ONE END AT A TIME.

5. From the bottom of the base, insert a bolt with bolt support through the slot in the top of the base so the raised portion of the bolt support goes into the slot, as shown in Figure 4.

FIGURE 2

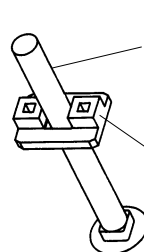

FIGURE 3

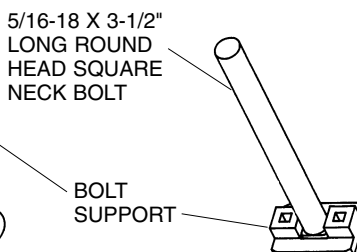

FIGURE 3A

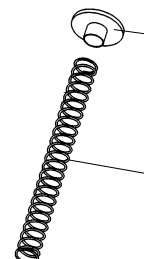

FIGURE 3B

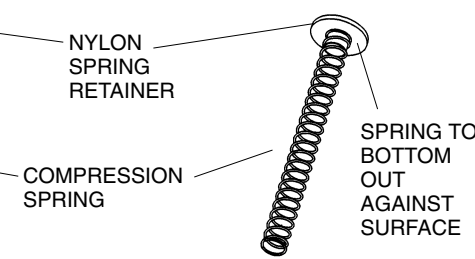
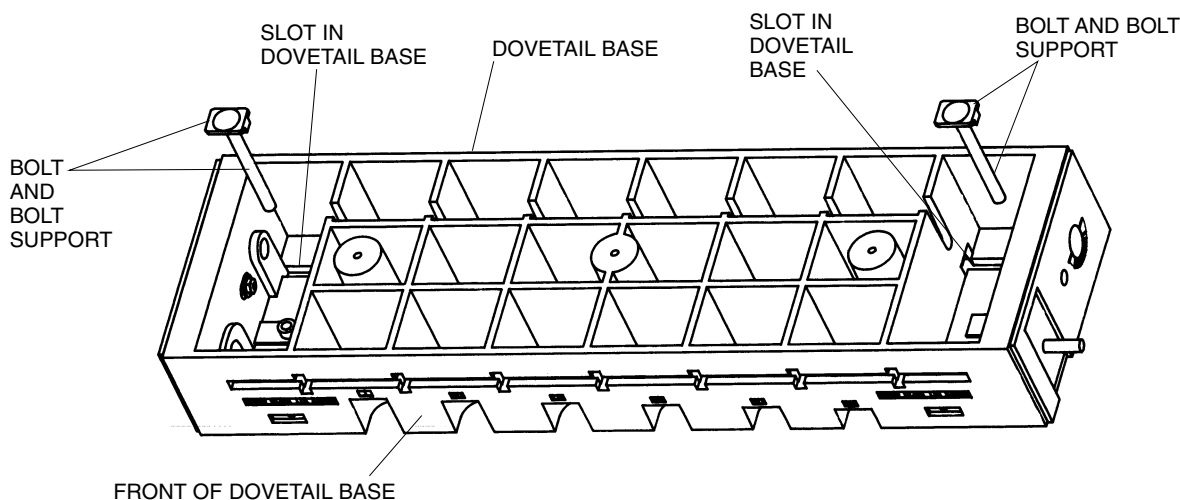

FIGURE 4



6. Place an 11/32" I.D. X 7/8" O.D. washer and then a 5/16" I.D. X 7/8" O.D. thick nylon washer over the bolt. It will be necessary to hold the bolt in place when performing this and the following steps.

HELPFUL HINTS: Position the bolt and the bolt support under the notch in the rib as shown in Figure 5, to help hold the bolt in place.

7. Place a spring over the bolt, as shown in Figure 6.

8. Place a 5/16" I.D. X 7/8" O.D. thick nylon washer and then an 11/32" I.D. X 7/8" O.D. washer over the bolt and press down on the spring until just the end of the bolt sticks out past the end of the washer.

9. Slide the clamping bar over the bolt so that the washers are sandwiched between the spring and the inside of the clamping bar as shown in Figure 6. **NOTE: THE SPRING MUST PUSH AGAINST THE THICK NYLON WASHERS AND NOT AGAINST THE STEEL WASHERS.**

10. Place an 11/32" I.D. X 7/8" O.D. thin nylon washer and an 11/32" I.D. X 7/8" O.D. washer over the bolt. It will be necessary for you to press down on the clamping bar while doing this.

11. Take one of the clamping knobs and thread it onto the bolt as shown. **DO NOT THREAD** the knob completely onto the bolt—just enough so the knob holds the clamping bar in place.

12. Repeat above steps 4 through 10 for the other end of the clamping bar.

13. Assemble the end caps to the ends of the clamping bar by pressing them in; they are designed to be "force-fit" into

FIGURE 5

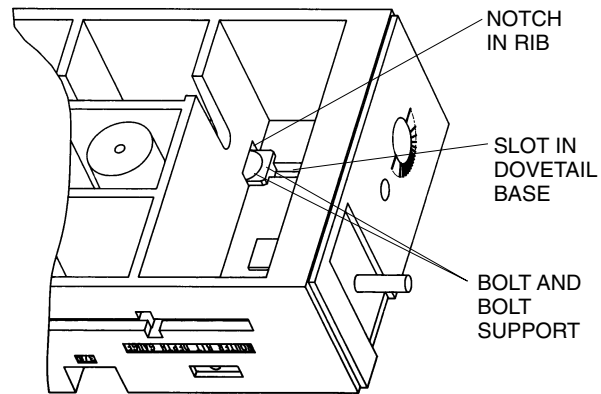

the bar in one way only. It may be necessary to "tap" them in by gently hitting them with a rubber mallet or a piece of wood—since they fit very tightly into the clamping bar. **USE CARE WHEN DOING THIS SO AS NOT TO DAMAGE THE END CAPS.**

USE CARE THAT THE CAPS ARE PROPERLY ALIGNED AS SHOWN WHEN ASSEMBLING THEM TO THE BAR.

14. Tighten the clamping knobs onto the bolts so that the space between the bottom of the clamping bar should be parallel to the top of the base.

15. After completing the above steps your Dovetail Jig should look like the illustration in Figure 7.

FIGURE 6 Assemble clamping bar, knobs, end caps on both ends as shown

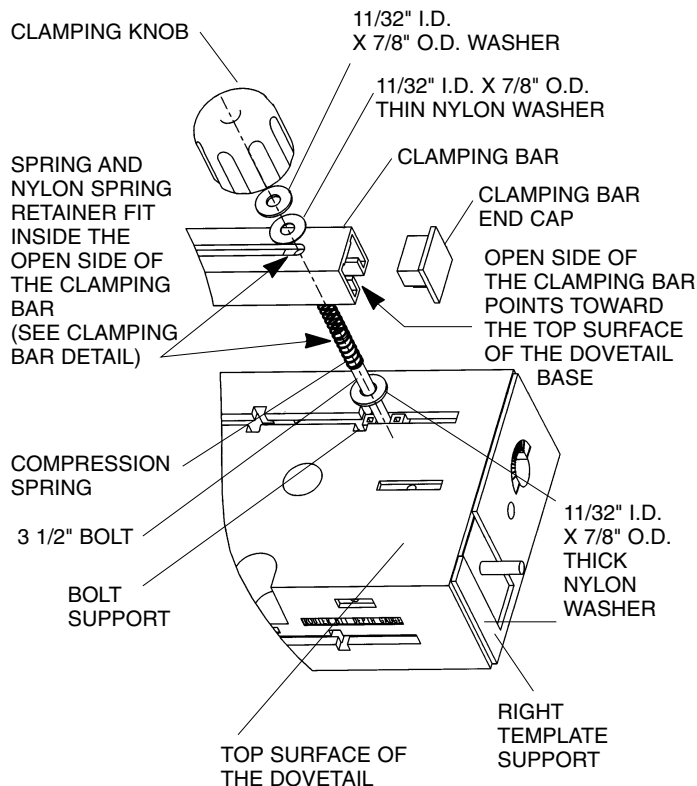

CLAMPING BAR DETAIL

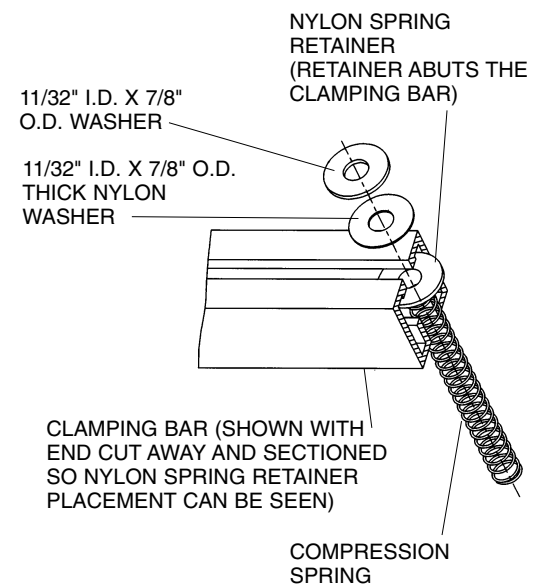
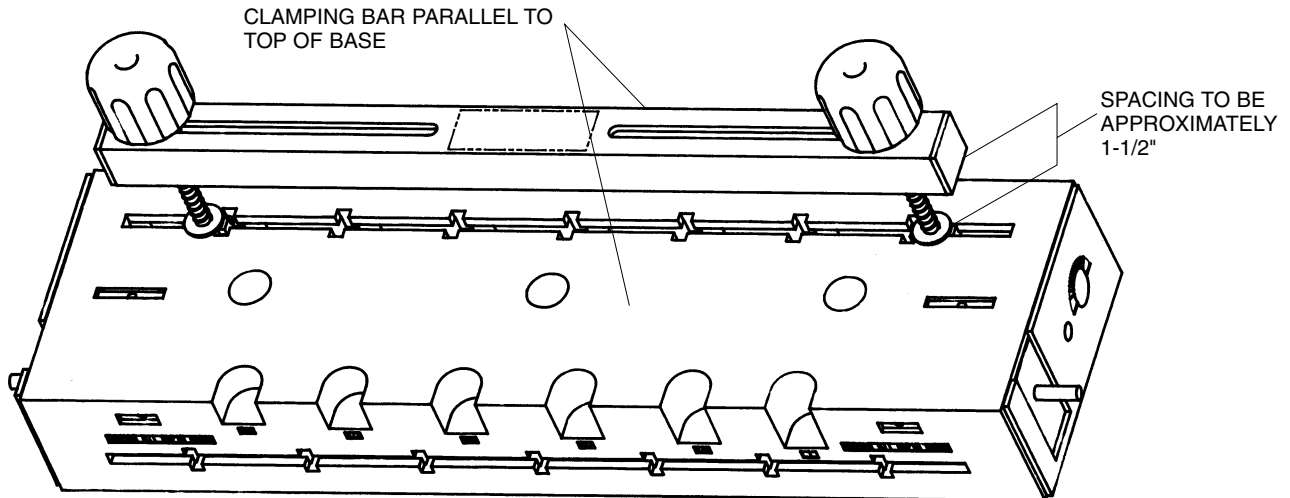

FIGURE 7



ASSEMBLY OF THE FRONT CLAMPING BAR TO THE DOVETAIL BASE

1. Assemble the front clamping bar to the front of the dovetail base following the same procedure used to assemble the top clamping bar to the dovetail base as shown in

Figure 8. The 5/16-18 X 4-1/2" long round head square neck bolts are used.

FIGURE 8

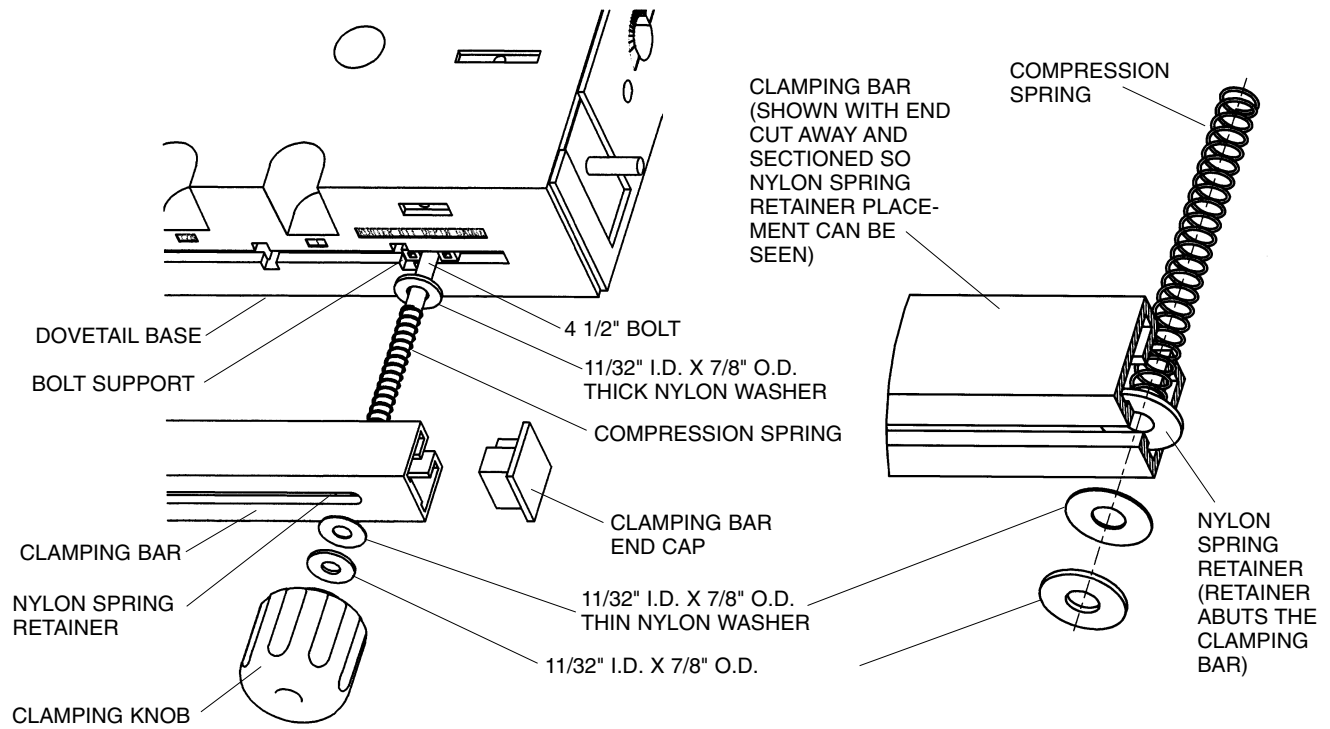

ASSEMBLY OF THE CAM HANDLES AND PIVOT SHAFT TO THE DOVETAIL BASE

- After the cam handles and pivot shaft have been assembled to the base, it will be possible to accurately position the templates for close fitting joints.
- Note that there are some graduations on both template supports.
- Rotating the cam handle so that the pointer lines up with one of the graduations permits accurate front-to-back positioning of the template.
- Cam handles are designed to provide infinite template adjustment.
- One graduation equals $1/64$ " of movement of the template.
- Rotating the cam handle so that the lever moves toward the front of the base, causes the template to also move towards the front of the base.
- Conversely rotating the cam handle so that the lever moves toward the back of the base, causes the template to also move towards the back of the base also.

1. Assemble one of the cam handles to the pivot shaft using a #10-32 x $5/8$ " long panhead machine screw and a $13/64$ " I.D. x $9/16$ " I.D. washer. as shown in Figure 9.
2. Use care so that the pivot shaft fits into the hex-shaped hole in the cam handle. The pivot shaft may fit tightly into the cam handle; this is normal.
3. Make sure that the pivot shaft bottoms-out inside the cam handle.
4. Securely tighten the screw.

NOTE: THE NEXT TWO STEPS ARE PRE-ASSEMBLY STEPS.

5. Slide the retainer over the end of the pivot shaft for about 2". The retainer may fit tightly; this is normal.
6. Thread the #10-16 x $1/2$ " long panhead tapping screw into the hole in the retainer until it bottoms-out against the pivot shaft. (The screw will fit tightly in the hole.) See Figure 10.

FIGURE 9

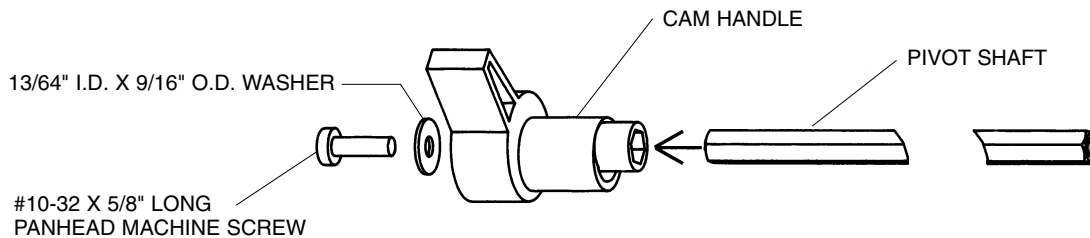
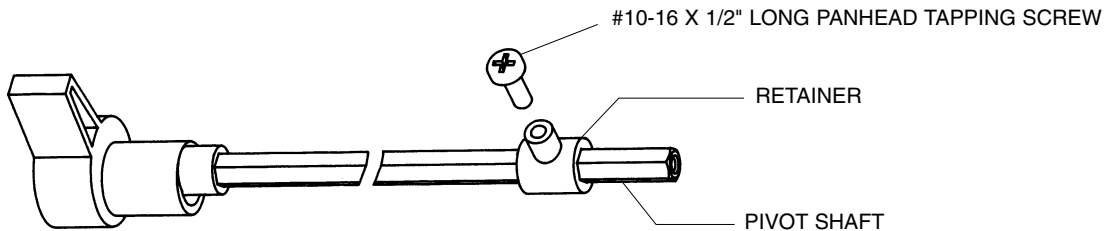

FIGURE 10



7. Loosen the screw about one turn. Remove the retainer from the shaft and set it aside temporarily.
8. Assemble the pivot shaft with cam handle to the base by inserting the end of the pivot shaft through the holes in the right template support and the base.
9. MAKE SURE THE ORIENTATION OF THE CAM HANDLE IS AS SHOWN IN FIGURE 11.
10. Place the retainer at the location shown in Figure 12 and push the pivot shaft through. THE ORIENTATION OF

THE RETAINER RELATIVE TO THE CAM HANDLE WITH SCREW MUST BE AS SHOWN.

NOTE: THE RETAINER MAY FIT TIGHTLY ON THE PIVOT SHAFT; THIS IS NORMAL.

11. Continue pushing the pivot shaft through the holes and the retainer until the end of the pivot shaft extends out of the left template support as shown in Figure 12.

12. Make sure the end of the cam handle fits into the hole in the base as shown.

FIGURE 11

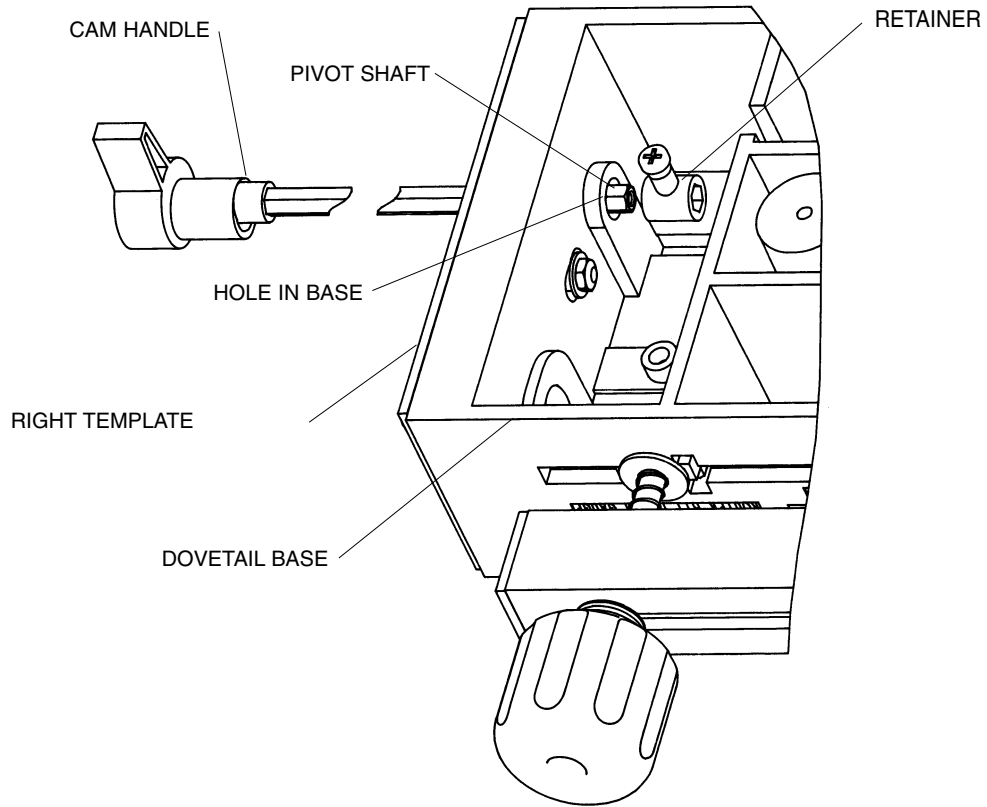
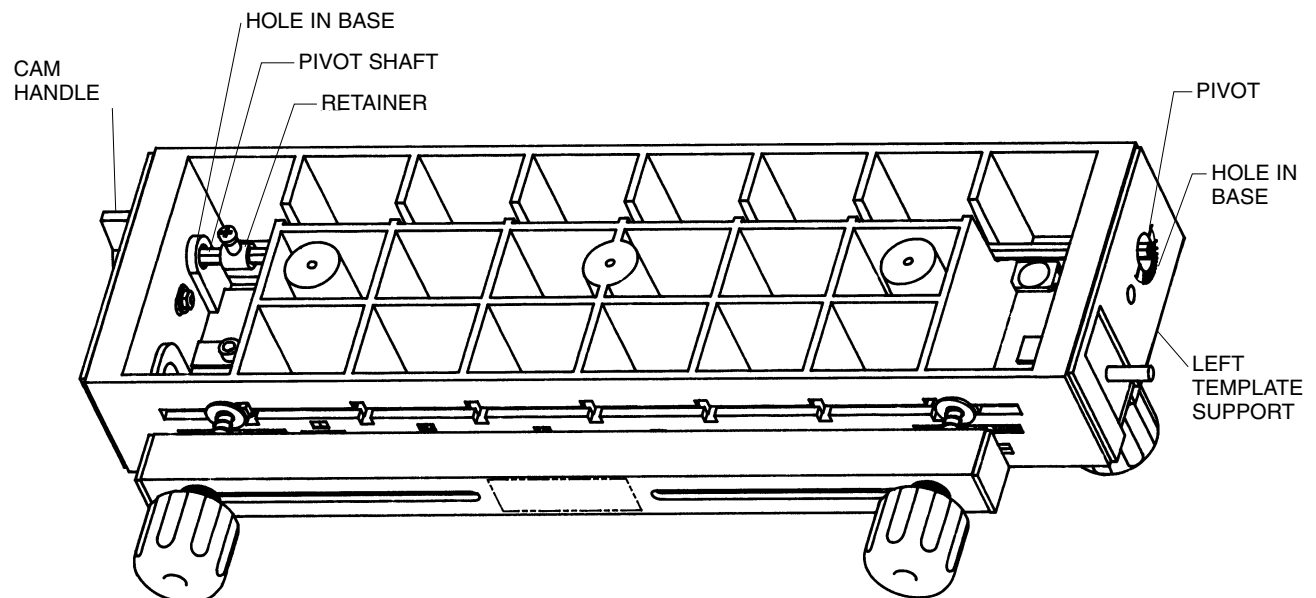

FIGURE 12



13. With the cam handle pushed in against the base, position the retainer against the side wall of the base, as shown in Figure 13. The retainer should barely touch the side wall of the base. The purpose of the retainer is to prevent or minimize the side-to-side of the cam handle and pivot shaft.

14. Assemble the other cam handle to the other end of the pivot shaft using a 13/64" I.D. x 9/16" O.D. washer and a #10-32 X 5/8" long panhead machine screw, as shown in Figure 14.

15. Make sure that the cam handle lines up with the cam handle at the other end of the pivot shaft and that the end

of the cam handle fits into the hole in the base.

16. Tighten the screw securely.

17. Rotate one of the cam handles—it should rotate freely and move the template supports

18. If this does not happen, loosen the screw on the retainer and move the retainer away from the side wall slightly.

19. Securely retighten the screw.

20. If there is too much side-to-side movement (play) of the cam handles; loosen the screw in the retainer and move the retainer closer to the side wall of the base.

21. Securely retighten the screw.

FIGURE 13

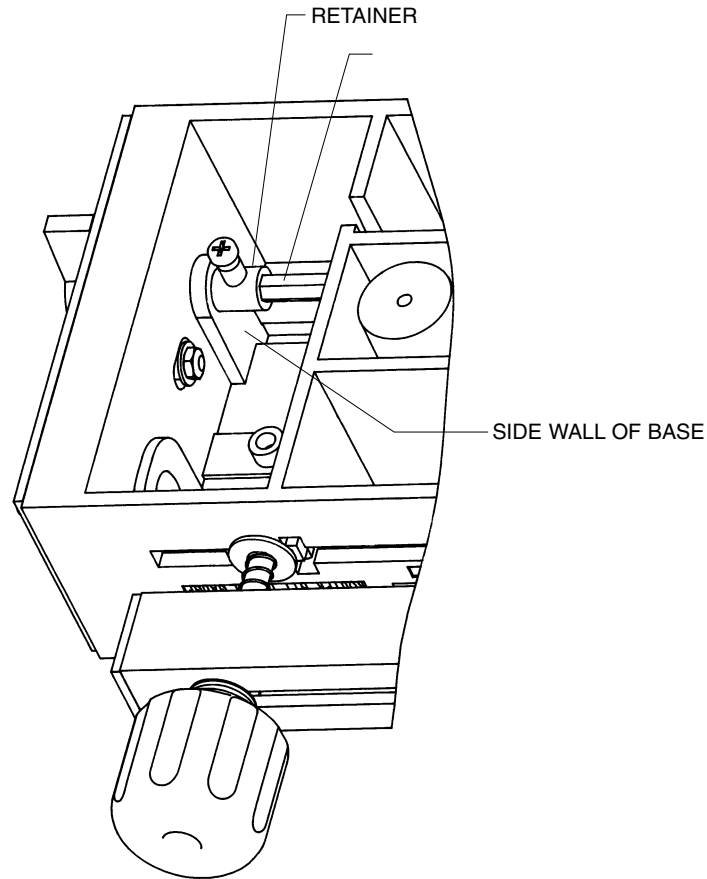
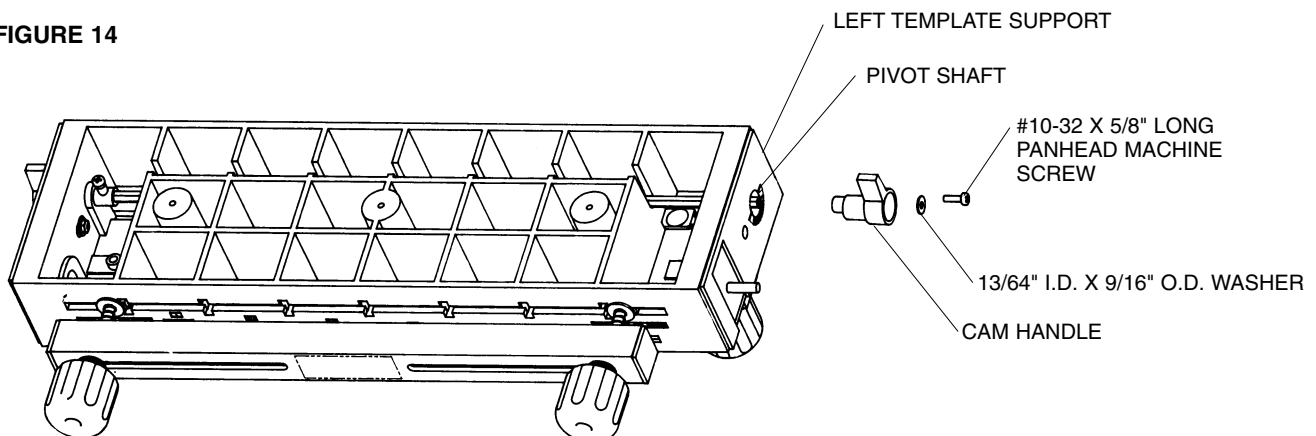

FIGURE 14



ASSEMBLY OF THE FRONT STOP BLOCKS TO THE DOVETAIL BASE

1. Assemble the front stop blocks to the front of the dovetail base, at each end, using #10-32 x 5/8" long flathead machine screws, 13/64" I.D. x 9/16" O.D. washers, and #10-32 hex nuts, as shown in Figure 15.
2. Make sure that the open rib portion fits into the slot in

the front of the base. The stop block will fit into the slot in one position only.

3. Tighten the screw securely onto the nut.
4. Assemble the other front stop block to opposite end of the dovetail base in the same manner.

FIGURE 15

FOR REASONS OF CLARITY, THE FRONT CLAMPING BAR, KNOBS, BOLTS AND SPRINGS ARE NOT SHOWN

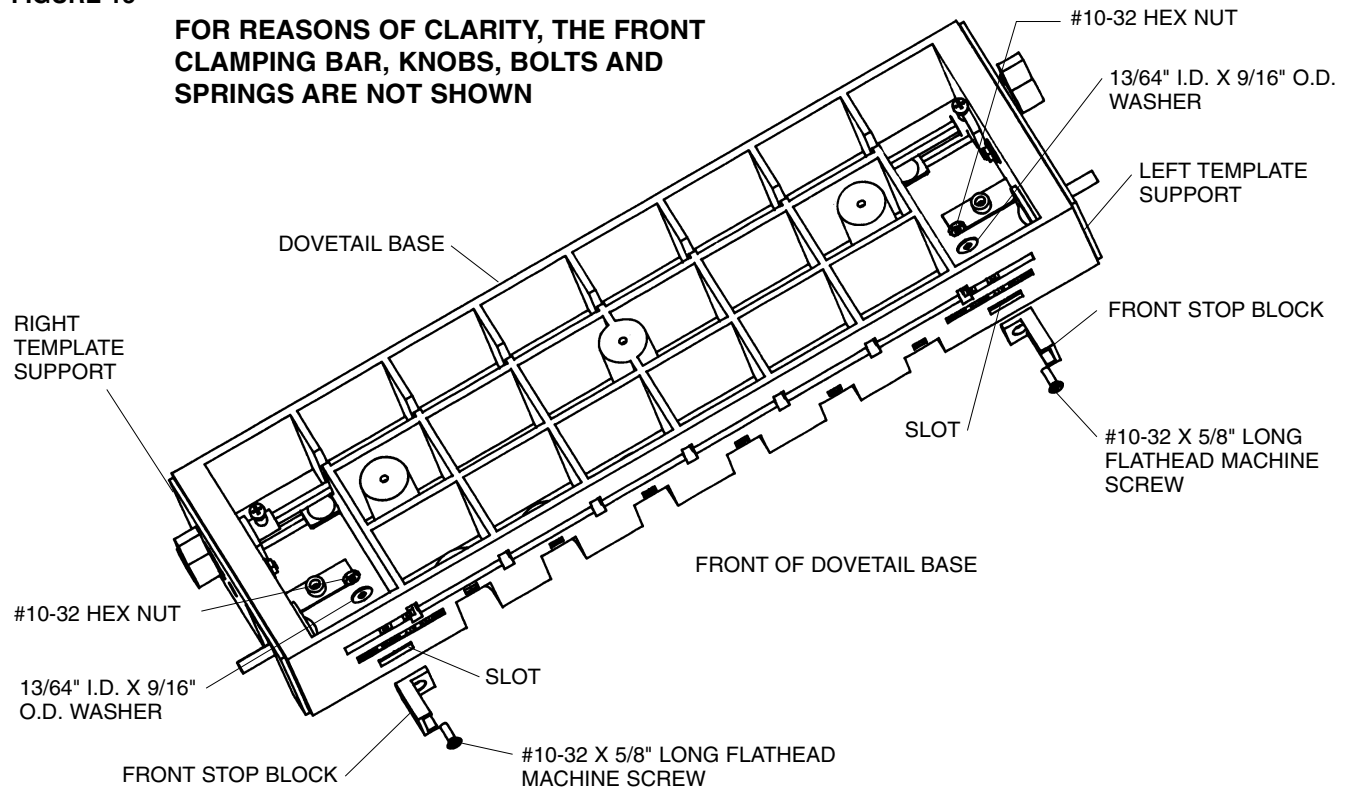

ASSEMBLY OF THE TOP STOP BLOCKS TO THE DOVETAIL BASE

- The top stop blocks are assembled to the top of the dovetail base in one of two ways depending upon which style of dovetail joint is to be cut:
 - a. HALF-BLIND FLUSH JOINTS—The “A” on the stop block faces toward the “middle of the base”.
 - b. HALF-BLIND RABBET JOINTS—The “B” on the stop block faces toward the “middle of the base”.
 - c. THROUGH JOINTS—The “A” on the stop block faces toward the “middle of the base”.
- Since the flush joint is the more commonly used joint, the following instructions apply to the assembly of the stop blocks for this style joint.
 1. Position the dovetail Jig right side up on a flat surface
 2. Assemble one of the top stop blocks to the top surface of the base using a #10-32 x 7/8" long flathead machine

3. Make sure that the “A” faces the “middle of the base”.
4. Make sure the open rib portion of the stop block fits into the slot in the top surface of the base.
5. Assemble the remaining top stop block to the opposite end of the base in the same manner
6. Again make sure that the “A” faces the “middle of the base”.
7. Tighten both screws securely.
8. To reposition the stop blocks for rabbet joints, simply loosen the screws just enough so that the ribs on the stop blocks come out of the slot. The stop block is then rotated 180° to the alternate position, so the “B” faces the middle of the base, and securely retighten the screws.

FIGURE 16

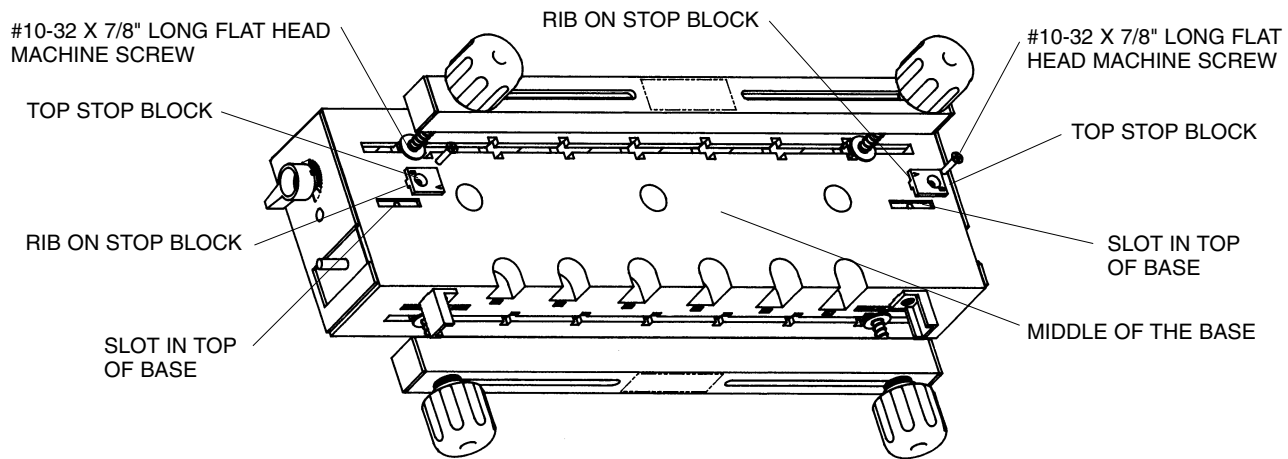

ASSEMBLY OF THE CLAMPING KNOBS TO THE DOVETAIL BASE

1. Assemble 11/32" I.D. x 7/8" O.D. washers onto the 5/16-18 bolts at both ends of the dovetail base as shown in Figure 17.
2. Assemble the clamping knobs onto the bolts as shown.

3. Thread the clamping knobs onto the bolts so that the spacing between the washer and the template supports is approximately 1/2".
4. Set the dovetail base aside for the time being and continue on with the next section.

FIGURE 17

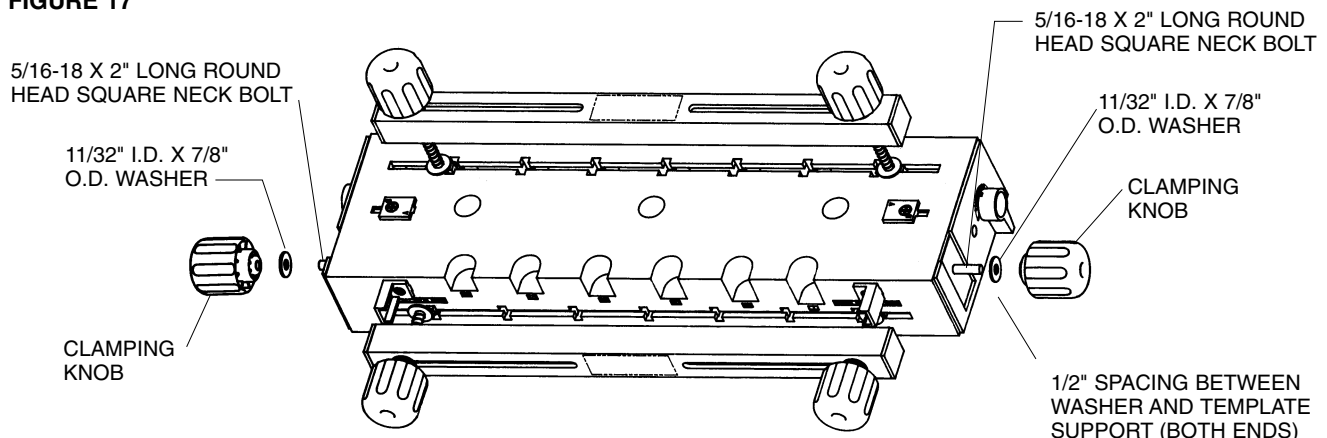

ASSEMBLY OF THE TEMPLATES

• Place the template stiffener into the rectangular slot in the underneath side of the template, as shown in Figure 18.

NOTE: THE TEMPLATE FOR CUTTING HALF-BLIND JOINTS IS BEING USED AS AN ILLUSTRATION IN THE FOLLOWING FIGURES.

1. Thread a #8-36 x 3/16" long panhead machine screw through each of the five holes in the template and into the threaded holes in the template support, as shown in Figure 18 and securely tighten all of the screws.

NOTE: ON SOME EARLY VERSIONS OF THIS PRODUCT, A SLOTTED BINDING HEAD MACHINE SCREW HAS BEEN SUBSTITUTED FOR THE PANHEAD SCREW SPECIFIED FOR ASSEMBLING THE TEMPLATE SUPPORTS TO THE TEMPLATES. (SEE THE SCREW ILLUSTRATION IN FIGURE 18.)

2. Assemble the template brackets to the template using four #10-32 x 3/8" long panhead machine screws, as shown in Figure 19.

3. MAKE SURE THAT THE TEMPLATE BRACKETS ARE ASSEMBLED TO THE UNDERNEATH SIDE OF THE TEMPLATE, AS SHOWN IN FIGURE 19, AND THAT THE ALIGNMENT OF THE BRACKETS IS ALSO AS SHOWN IN THE FIGURE.

4. IT IS NOT NECESSARY FOR THE SCREWS TO BE TIGHTENED AT THIS STAGE; THE TEMPLATE BRACKETS SHOULD BE FREE TO MOVE WITH RESPECT TO THE TEMPLATE OR ELSE IT WILL NOT BE POSSIBLE TO ALIGN THE TEMPLATE AS DESCRIBED IN THE NEXT SECTION.

5. The assembled template should look like the illustration in Figure 20.

6. Assemble the template stiffener and the template brackets to the TEMPLATE FOR CUTTING THROUGH JOINTS using the same method described in the preceding steps 1 through 5. Refer to Figure 20.

FIGURE 18

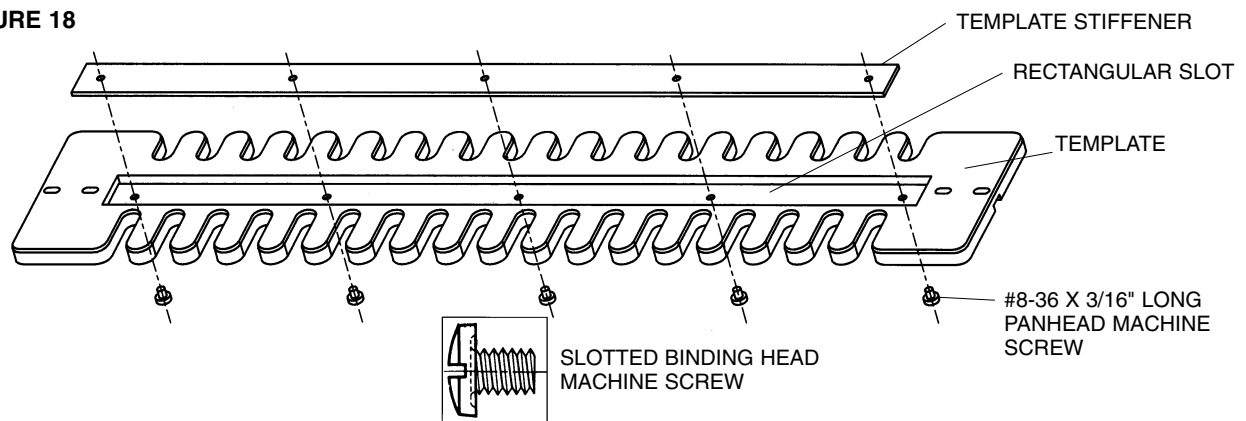

FIGURE 19

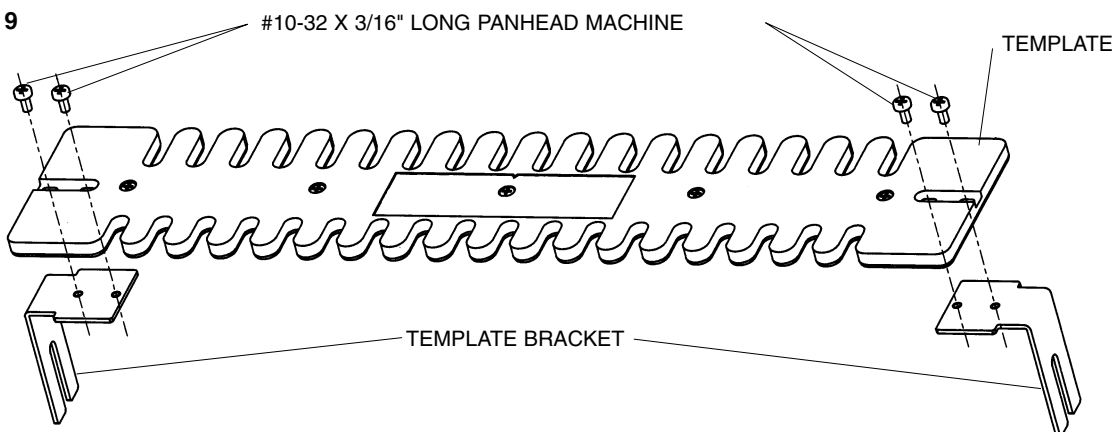
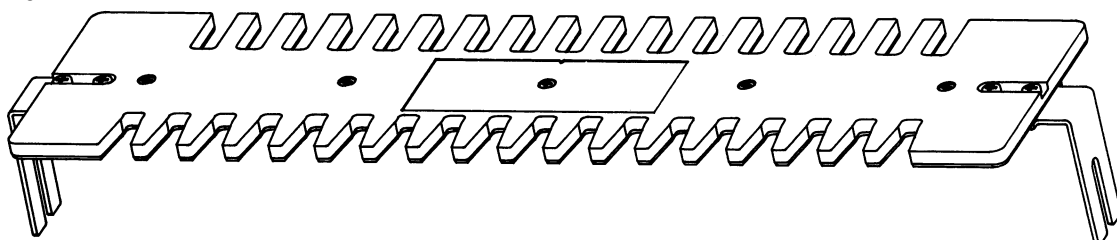

FIGURE 20



ALIGNMENT OF THE TEMPLATES

• In order for the Dovetail Jig to function properly, it is necessary for the templates to be aligned with respect to dovetail base. The reason for this, is that dovetail cuts are at both ends of the Dovetail Jig. When properly aligned, the result being all mating corners will always be lined up.

• **NOTE: THE TEMPLATE FOR CUTTING HALF-BLIND JOINTS IS BEING USED AS AN ILLUSTRATION IN THE FOLLOWING FIGURES.**

1. With the dovetail base still having the 1/2" spacing between the washer and the template supports (Refer to Figure 17), assemble the template assembly to the dovetail base so that:

- a) the slot in the template bracket fits over the bolt
- b) the leg of the template bracket is between the washer and the template support, and
- c) the legs fit into the slots in the template supports, as shown in Figure 21.

d) **NOTE: THIS PROCEDURE MUST BE FOLLOWED WHENEVER THE TEMPLATE IS INSTALLED ON THE DOVETAIL JIG. IT IS MOST IMPORTANT THAT LEG OF THE TEMPLATE BRACKET ALWAYS BE BETWEEN THE WASHER AND THE TEMPLATE SUPPORT OR ELSE THE TEMPLATE WILL NOT BE PROPERLY POSITIONED FOR CUTTING ACCURATE DOVETAILS.**

For initial setup, Allow the legs of the template bracket to "bottom out" in the slots in the template supports as shown in Figure 21.

• **TO REMOVE THE TEMPLATE FROM THE DOVETAIL JIG, LOOSEN THE CLAMPING KNOBS SO THAT SPACING BETWEEN THE TEMPLATE BRACKET AND THE WASHER IS ABOUT 1/2"; GENTLY LIFT THE TEMPLATE UPWARD FROM THE DOVETAIL BASE SO THAT THE TEMPLATE BRACKET CLEARS THE SLOTS IN THE TEMPLATE SUPPORT AND STORE IN A CONVENIENT LOCATION.**

2. Lightly tighten the clamping knobs at both ends of the base so that the template brackets are held in place against the template supports as shown in Figure 21.

3. Move the template from side to side on the template brackets so that it is centered with respect to the template brackets. This means that the template and brackets should look like one of the following figures: Figure 22, Figure 23. or Figure 24. Move template front-to-back so that front edge of template is parallel with the front of the dovetail base. In each condition the template and the template brackets **MUST** be symmetrical with each other. The figures do not show the complete Dovetail Jig, but only the underneath side of the template with template brackets correctly positioned, in order that the correct positions of

FIGURE 21

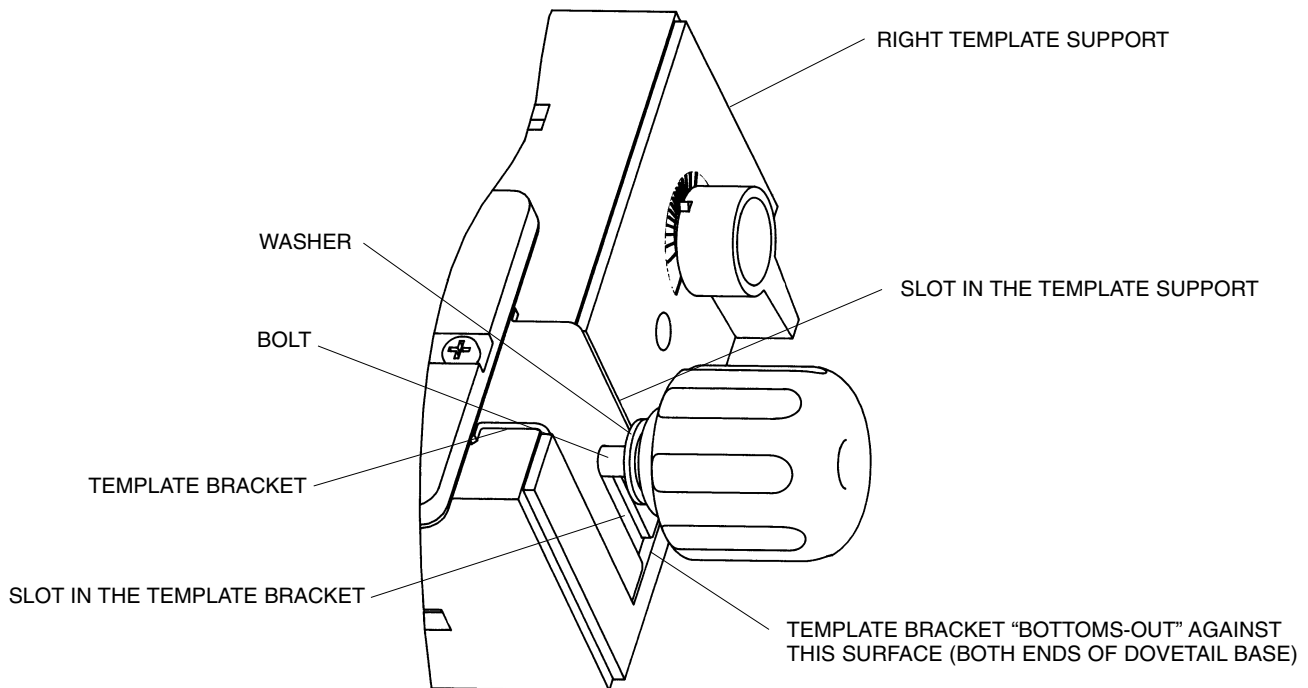
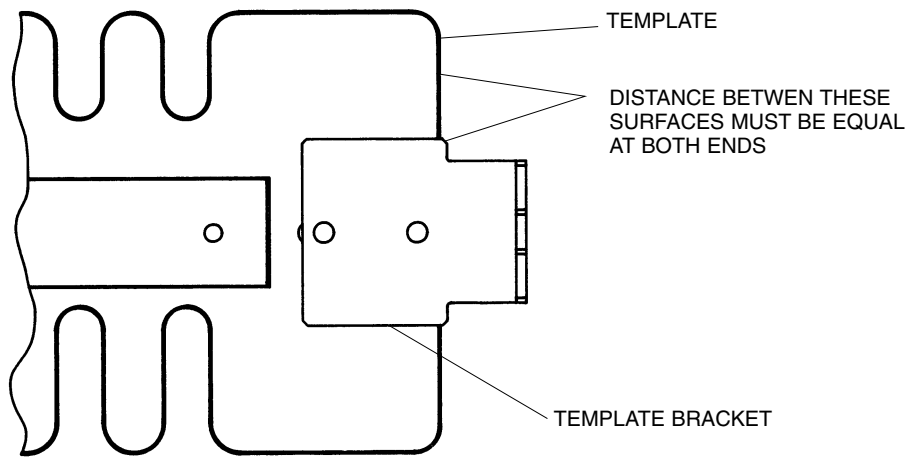
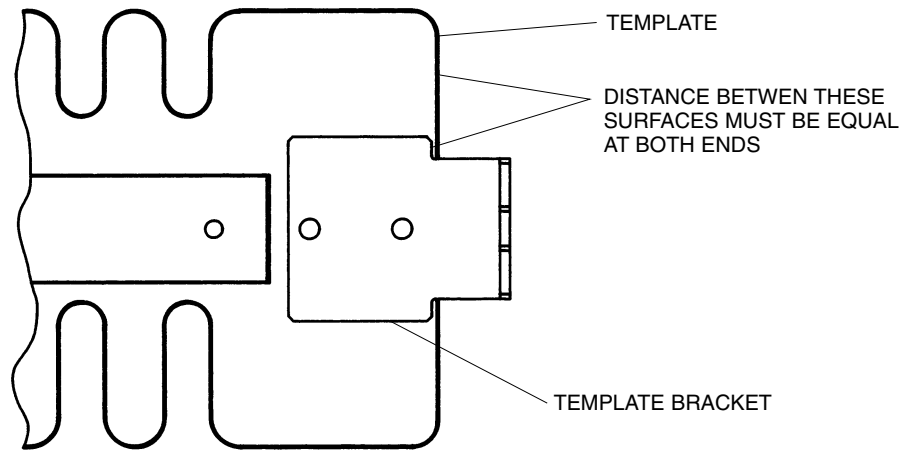

FIGURE 22



CONDITION ONE: TEMPLATE BRACKETS PROTRUDE BEYOND TEMPLATES

FIGURE 23



CONDITION TWO: TEMPLATE PROTRUDES BEYOND TEMPLATES BRACKETS

FIGURE 24

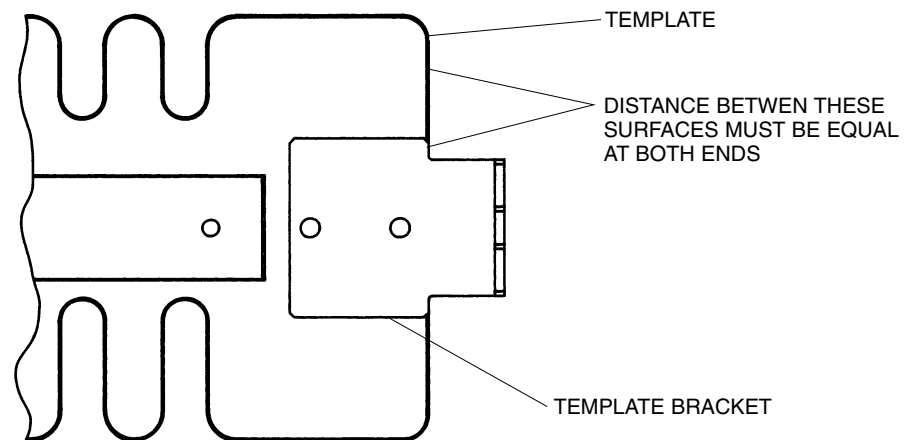

CONDITION THREE: TEMPLATE EVEN WITH TEMPLATE BRACKETS

4. After the template brackets have been correctly positioned on the template securely tighten the four screws holding the template brackets to the template.
5. Remove the template assembly from the base and set it aside for now.
6. Align the other template assembly in the same manner.

IT SHOULD BE NOTED THAT YOU MAY FIND, THAT AFTER MAKING SOME SAMPLE CUTS, SLIGHT

ADJUSTMENTS MAY BE REQUIRED. HOW TO MAKE THESE ADJUSTMENTS IS EXPLAINED IN TWO OF THE FOLLOWING SECTIONS: "TROUBLESHOOTING FOR HALF BLIND JOINTS" or "TROUBLESHOOTING FOR OPEN (THROUGH) JOINTS".

7. Remove the template assembly from the base and set it aside for now. (Figure 25 below, is an example of INCORRECTLY positioned template brackets.)

FIGURE 25

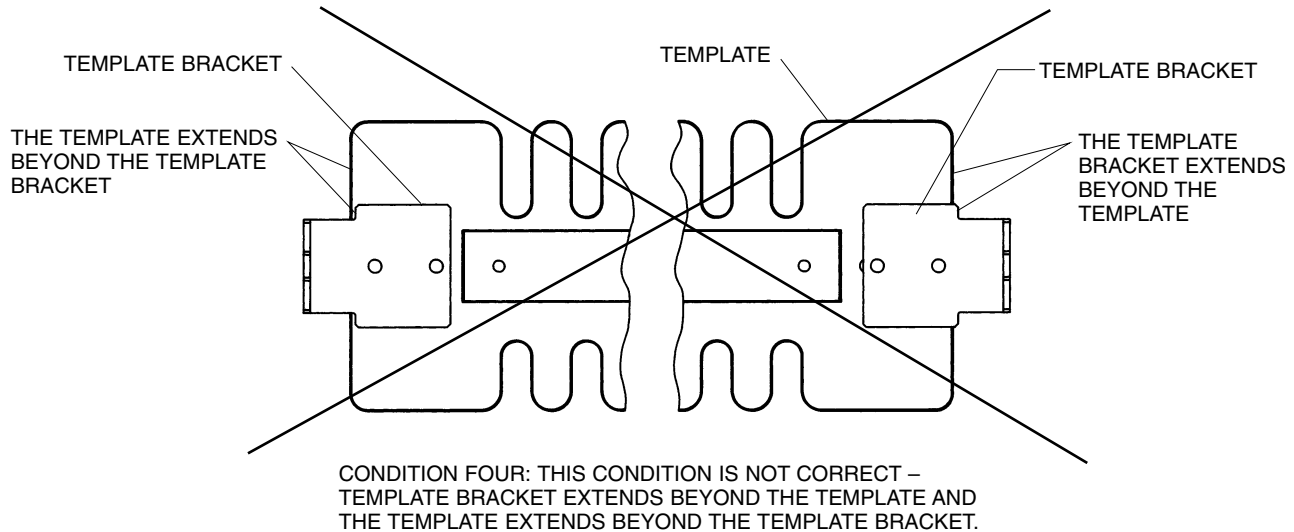

- SIMPLY MAKE SURE BRACKETS ARE POSITIONED THE SAME AT EACH END

ASSEMBLY OF THE ADAPTER PLATE TO THE ROUTER



WARNING
ALWAYS MAKE SURE THAT THE ROUTER IS "TURNED OFF" AND THAT THE ELECTRICAL CORD HAS BEEN UNPLUGGED FROM THE ELECTRICAL OUTLET BEFORE ASSEMBLING THE ADAPTER PLATE AND A GUIDE BUSHING TO THE ROUTER; OR WHEN MAKING ANY ADJUSTMENTS, OR CHANGING ROUTER BITS IN THE ROUTER.

1. Remove any router bit currently installed in the router.

2. Remove the router base plate now on the router, by removing the screws holding the base plate to the router.
3. Depending on the make of router, either three or four of the following screw types and sizes will have been used:

- a) #8 (.164 dia) Pan Head Screw
- b) #10 (.190 dia) Pan Head Screw
- c) #8 (.164 dia) Flat Countersunk Head Screw
- d) #10 (.190 dia) Flat Countersunk Head Screw

4. Compare the screws removed with those shown in Figure 26.

FIGURE 26

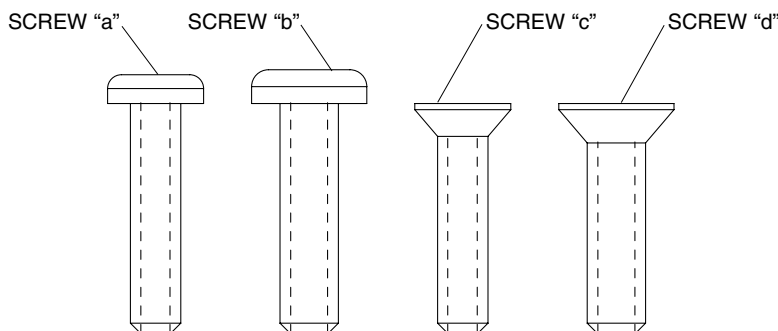

5. If the screws look like Screw "a" or Screw "b", use either three or four of the 13/64" ID x 15/32" OD washers when installing the adapter plate to the router as shown in Figure 27.
6. Your Dovetail Jig comes with four countersunk bushings with an 11/64" hole and four countersunk bushings with a 13/64" hole. Refer to Figure 28.

7. If the screws look like Screw "c", use either three or four of the bushings with an 11/64" dia. hole when installing the adapter plate to the router as shown in Figure 29.
8. If the screws look like Screw "d", use either three or four of the bushings with a 13/64" dia. hole when installing the adapter plate to the router as shown above in Figure 29.

FIGURE 27

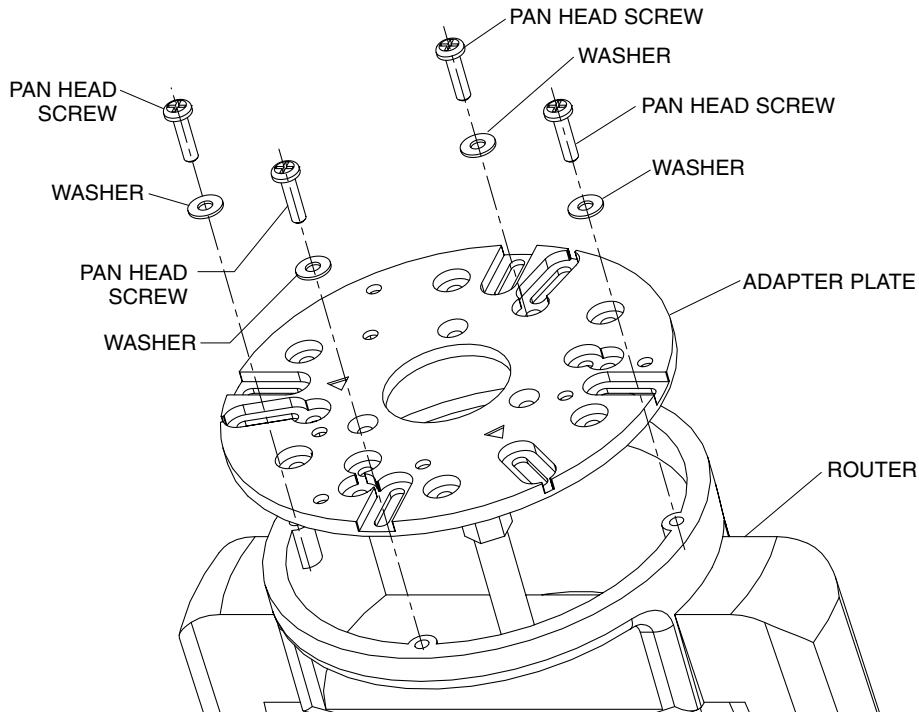

FIGURE 28

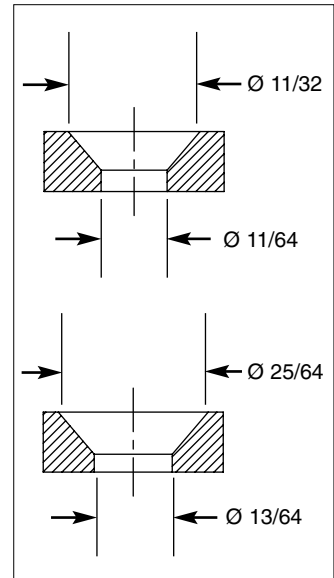
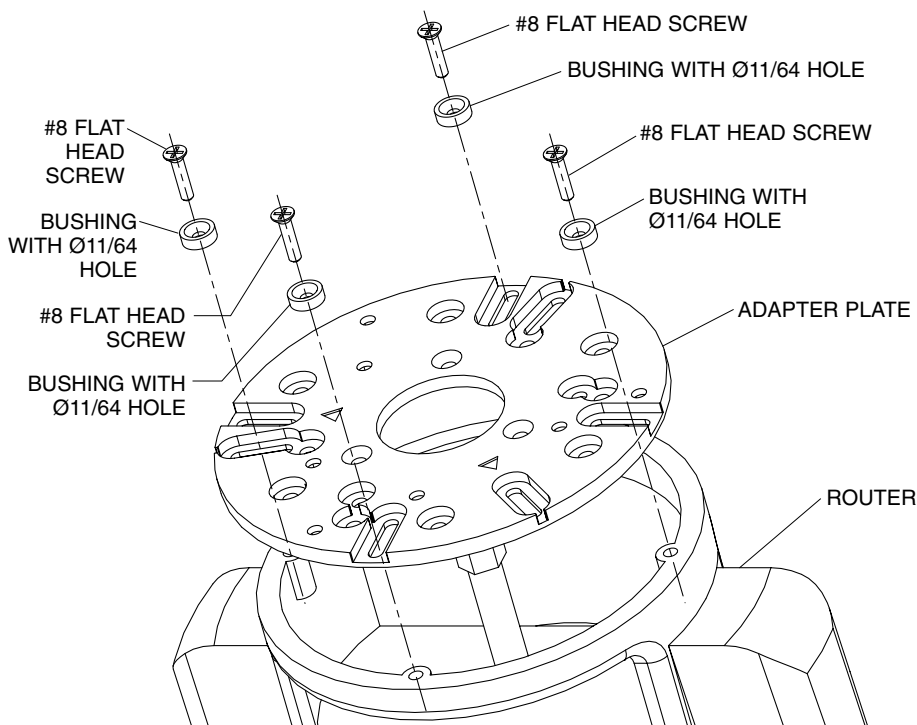

FIGURE 29



The figures below show the views of the adapter plate as it would appear when installed on a router with the router turned over with the router base facing upward. Three of the most popular mounting hole configurations are shown.

Figure 30 shows the mounting arrangement using three screws.

Figure 31 shows the mounting arrangement using four screws when the screws are at 45 degrees to the side of the front of the router.

Figure 32 shows the mounting arrangement using four screws when the screws are in line with the front of the router.

In most cases, the adapter plate will fit your router. However, in those cases where the router is extremely small or extremely large, rated at 1-3/4 HP or larger, the adapter plate cannot be used.

9. Set the router upside down on a workbench or other flat stable surface.

10. Position the adapter plate on the router so that the threaded holes in the router base line-up with slots (or holes) in the adapter plate.

The recessed arrow in the adapter plate should point

toward the front of the router.)

11. Line-up the center of the hole in the adapter plate with the collet hole in the router. This will ensure accurate cuts.

12. Using the screws removed in Step 2 above, in combination with either the washers or countersunk bushings, assemble the adapter plate to the router. If the bushing are used the heads of the screws must be flush with, or slightly below the top of the bushing.

THE TOPS OF THE SCREWS MUST NOT PROTRUDE ABOVE THE TOP SURFACE OF THE ADAPTER PLATE.

If for some reason the countersunk head screws being used are too short, too long, or protrude above the top of the adapter plate, obtain pan head screws that are 1/4" or 3/8" long with the proper thread from a hardware store or DIY outlet. Use these with the washers, instead of the bushings, to assemble the adapter plate to the router.

13. **TIGHTEN ALL SCREWS SECURELY.**

14. Check to see that center of the router collet hole still lines-up with the large center hole in the adapter plate.

15. If it does not loosen the screws and reposition the adapter plate so the hole lines-up with the router collet hole.

16. **TIGHTEN ALL SCREWS SECURELY.**

FIGURE 30

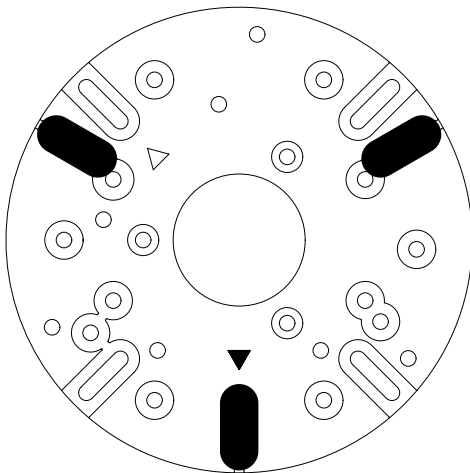

FIGURE 32

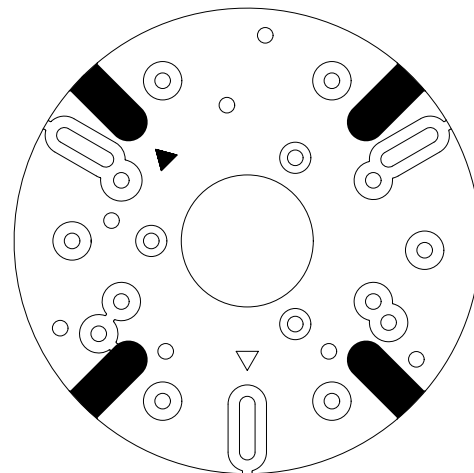
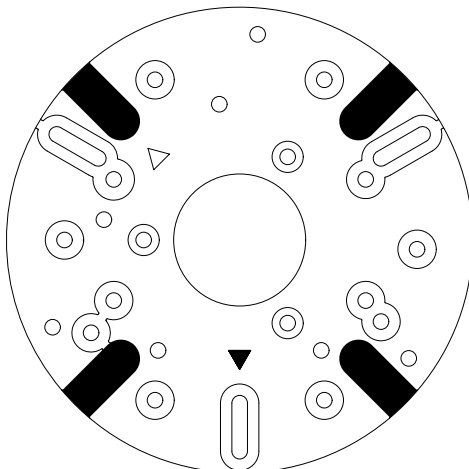

FIGURE 31



ASSEMBLY OF THE GUIDE BUSHING TO THE ROUTER

1. Place the router upside down on a flat surface. For certain routers it may be necessary to support the router for it to remain in this position.
2. Place the proper guide bushing required for the type of dovetail to be cut under the router adapter plate as shown in Figure 33.
3. MAKE SURE THAT THE ORIENTATION OF THE GUIDE BUSHING IS AS SHOWN.
4. Position the guide bushing so that the three threaded holes in the guide bushing line-up with the countersunk holes in the adapter plate.
5. Thread a #10-32 x 3/8" long flathead machine screw into each of the holes.
6. SECURELY TIGHTEN THE SCREWS. Refer to Figure 34.

FIGURE 33

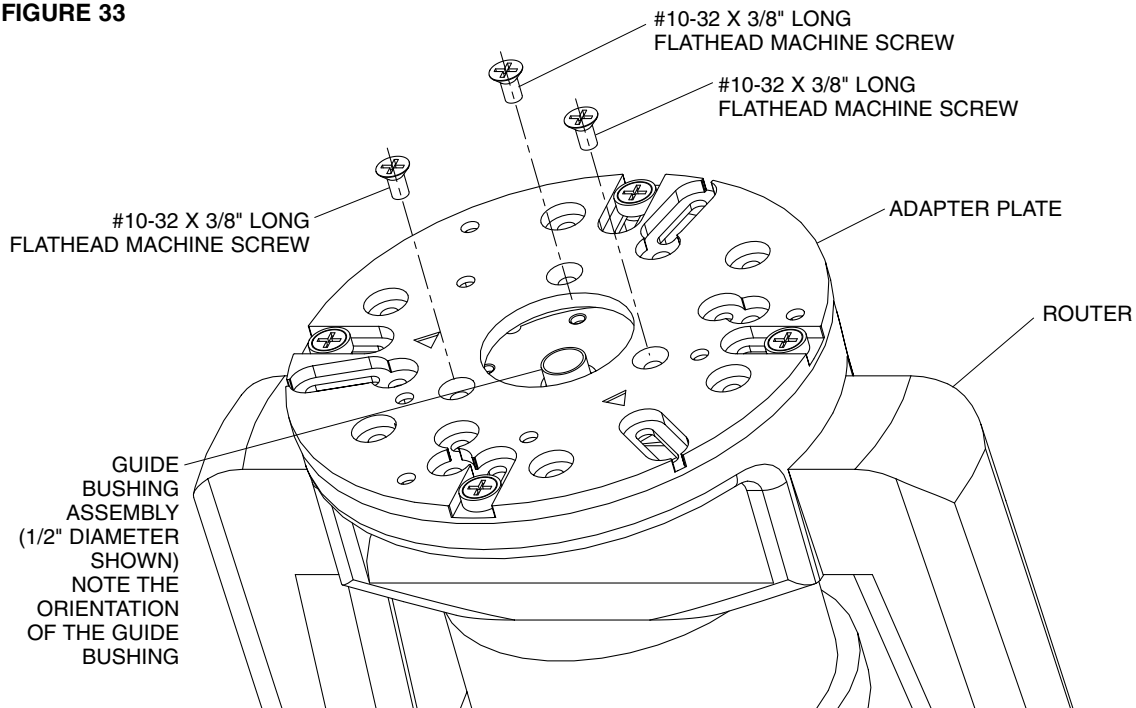
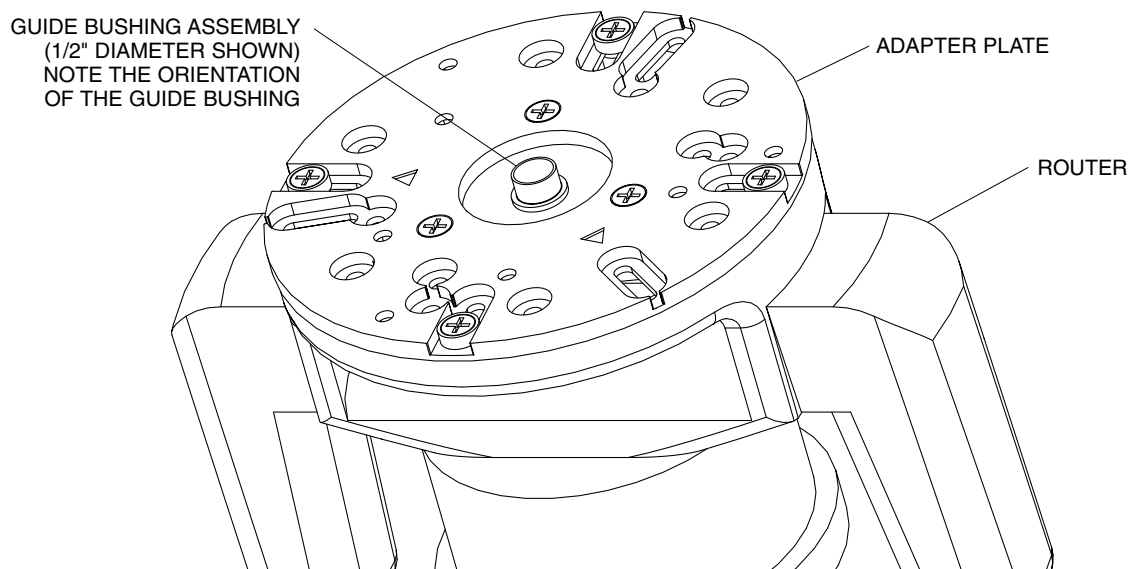

FIGURE 34



INSTALLATION

WARNING THE DOVETAIL JIG MUST ALWAYS BE FIRMLY AND SECURELY MOUNTED TO A SOLID AND FIRM WORK SURFACE, SUCH AS A WORKBENCH, BEFORE USE. FAILURE TO DO SO COULD CAUSE THE DOVETAIL JIG TO TIP OVER OR SLIDE ALONG THE WORK SURFACE, RESULTING IN PROPERTY DAMAGE AND SERIOUS PERSONAL INJURY.

MOUNTING THE DOVETAIL JIG TO A WORK SURFACE OR WORKBENCH USING CLAMPS.

USING THIS MOUNTING METHOD ALLOWS YOU TO MOUNT THE DOVETAIL JIG SO THAT IT CAN BE EASILY INSTALLED, FOR USE, AND REMOVED, FOR STORAGE, WITHOUT PERMANENTLY TAKING UP SPACE ON YOUR WORKBENCH.

1. Make a solid wood mounting board, 32" long x 6-1/4" wide x 3/4" thick.

2. Remove the template assembly from the dovetail base if there is one there currently.
3. Drill three 1/8" diameter holes, 3/4" deep into the mounting board as shown in illustration.
4. Position the Dovetail Jig on the top of the mounting board so the holes in the base line up with the drilled holes in the mounting board.
5. Secure the Dovetail Jig to the mounting board using three 13/64" I.D. x 9/16" O. D. washers and three #10-16 x 1" long panhead self tapping screws as shown in Figure 35.
9. Applying a small amount of soap to the screw threads will make it easier to thread the screws into the holes.
10. Line up the front of the mounting board with the front of a workbench or other sturdy surface.
11. Using two clamps, such as C-clamps, firmly clamp the Dovetail Jig to the workbench by clamping on the mounting board as shown in Figure 36 and Figure 36A.
12. Make sure that the mounting board lines up with the front of the workbench.

FIGURE 35

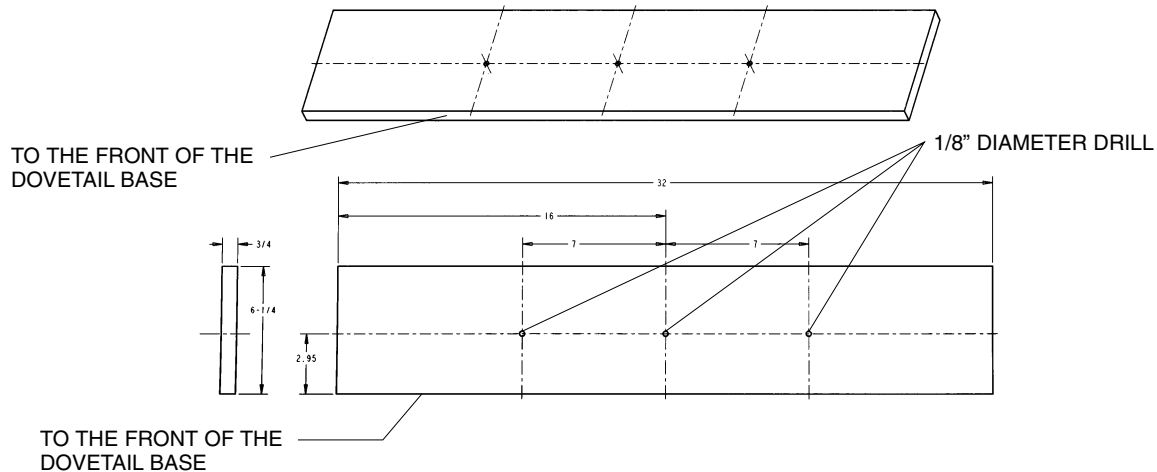

FIGURE 36

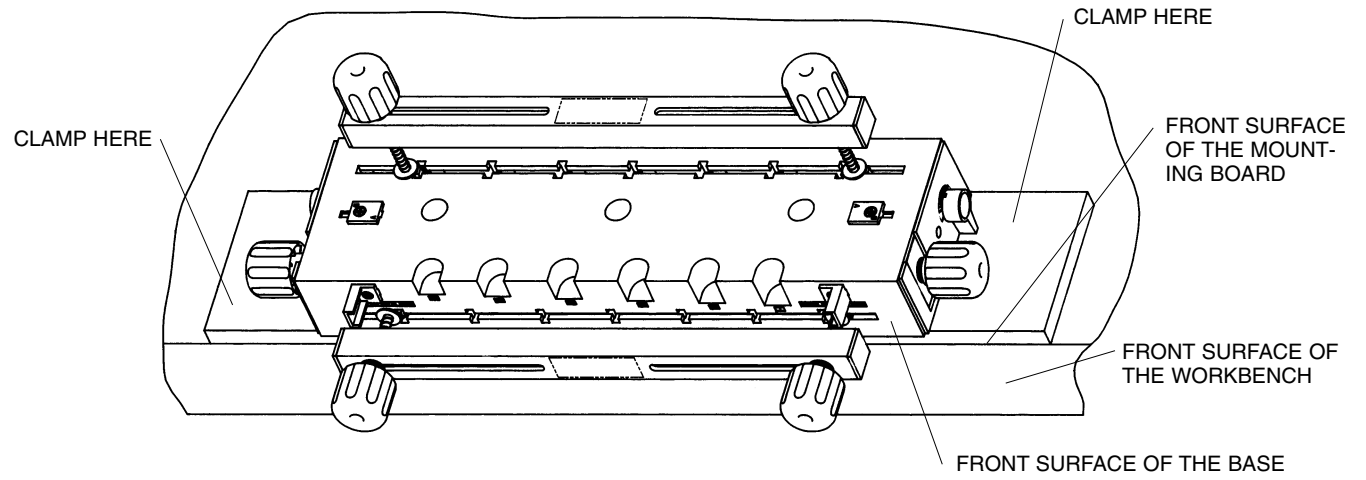
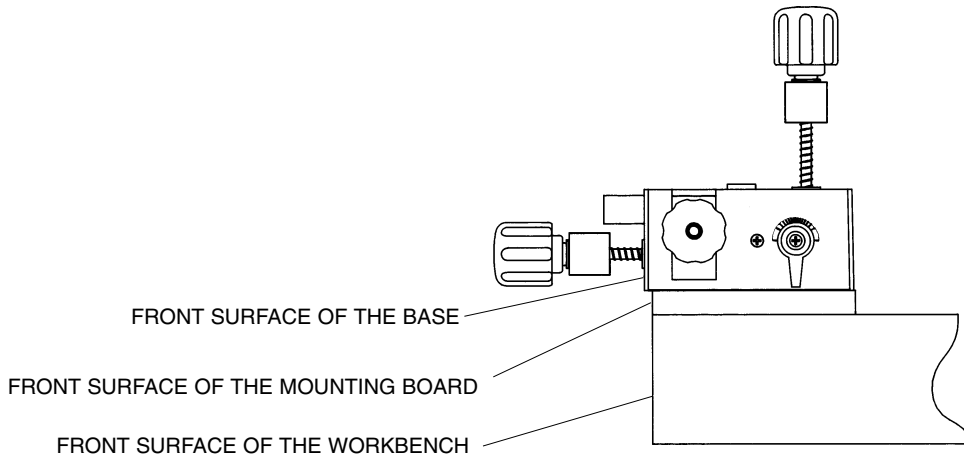

FIGURE 36A



OPERATION

STYLES OF DOVETAIL JOINTS

- Four different styles of dovetail joints can be made with the Dovetail Jig using your router.
- These joints are described in the following sections.

Half Blind Flush Joint

- The **Half Blind Flush Joint** is used when the height of both the drawer front and the drawer back is the same height as the drawer sides; and the length of both the drawer front and the drawer back is the same as the width of the drawer.
See Figure 37.

NOTE: THE NORMAL DEPTH OF CUT FOR A HALF BLIND FLUSH JOINT IS 3/8".

FIGURE 37

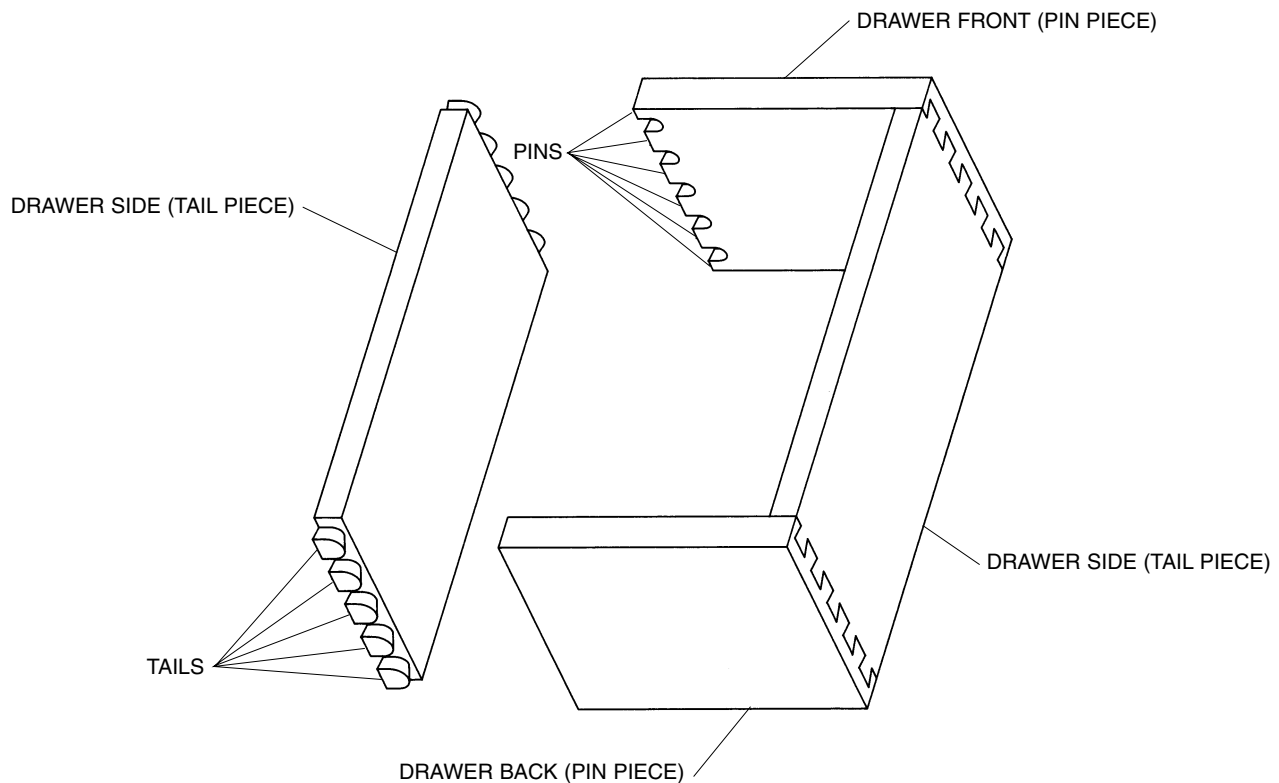

Half Blind Flush Offset Joint

- The **Half Blind Flush Offset Joint** is used when: The height of both the drawer front and the drawer back is the same height as the drawer sides; the length of the drawer front is 1/8" longer (1/16" on a side) than the width of the drawer; and the length of the drawer back is the same as the width of the drawer.

See Figure 38.

- To obtain the offset, cut a 1/16" deep by 3/8" wide rabbet on the opposite ends on the inside of the drawer front.

NOTE: THE NORMAL DEPTH OF CUT FOR A HALF BLIND FLUSH OFFSET JOINT IS 3/8".

FIGURE 38

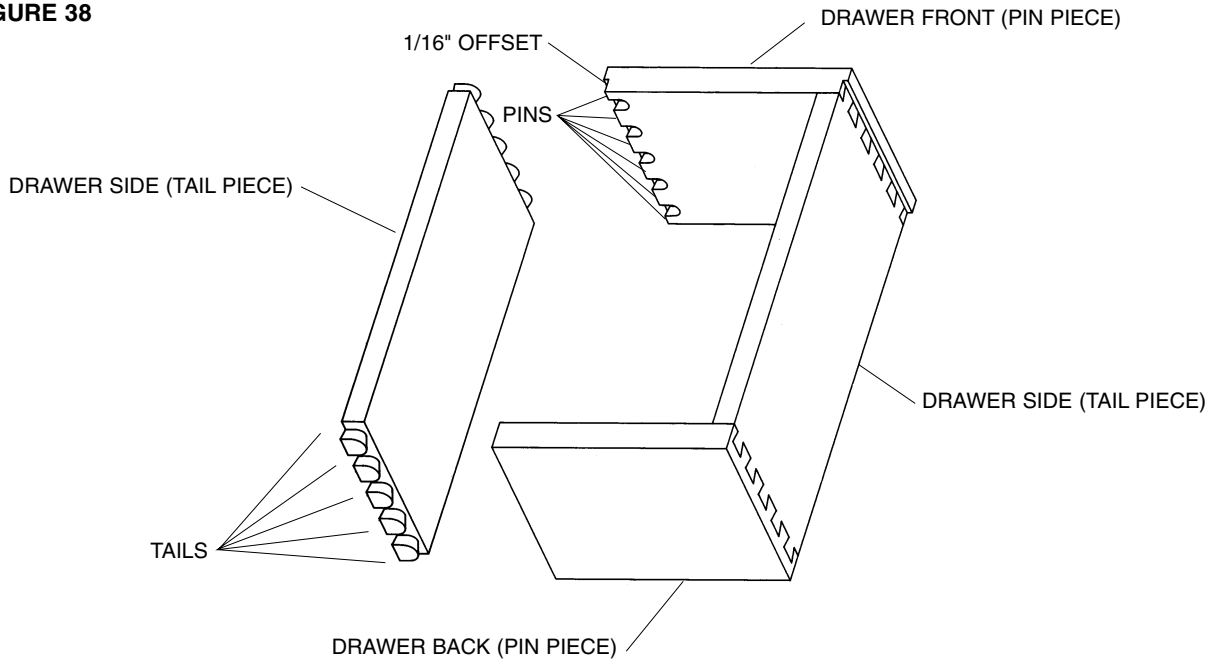

Half Blind Rabbeted Joint

- The **Half Blind Rabbeted Joint** is used when: The drawer front overlaps the opening for the drawer on all four sides of the of the drawer opening (top, bottom, and two sides) that is; the length of the drawer front is 3/4" longer (3/8" on a side) than the width of the drawer; the height of the drawer front is also 3/4" higher (3/8" on side) than the height of the drawer; the length of the drawer back

is the same as the width of the drawer; and the height of the drawer back is the same as the height of the drawer. See Figure 39.

- To obtain this joint, cut a 3/8" deep by 3/8" wide rabbet around the inside periphery of the drawer front.

NOTE: THE NORMAL DEPTH OF CUT FOR A HALF BLIND RABBETED JOINT IS 3/8".

FIGURE 39

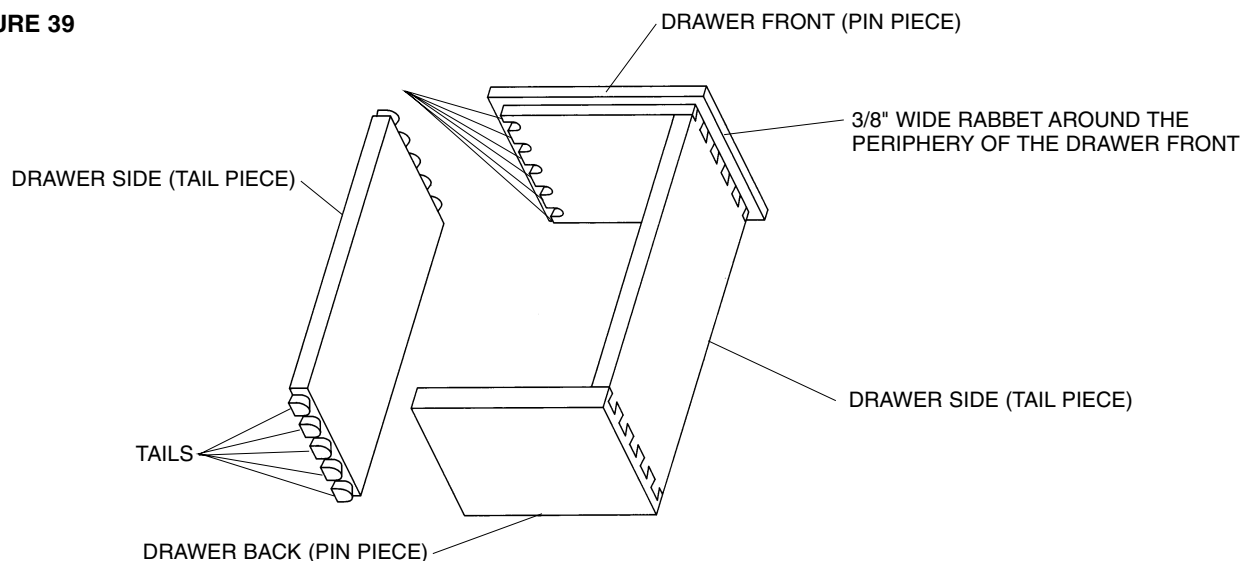

Open or Through Joint

- The **Open or Through Joint** is similar to the Half Blind Joint except that joint seams are visible on the front, back, and sides of the workpiece; on the Half Blind Joints, the seams are visible only on the sides of the workpiece.
- Although this style of joint can be also used for drawers, its most popular use is for making boxes, and small and large chests.
- The height of both the front and the back of the drawer or chest is the same height as the sides of the drawer or chest; and the length of both the front and the back of the drawer or chest is the same as the width of the drawer or chest.

See Figure 40.

FIGURE 40

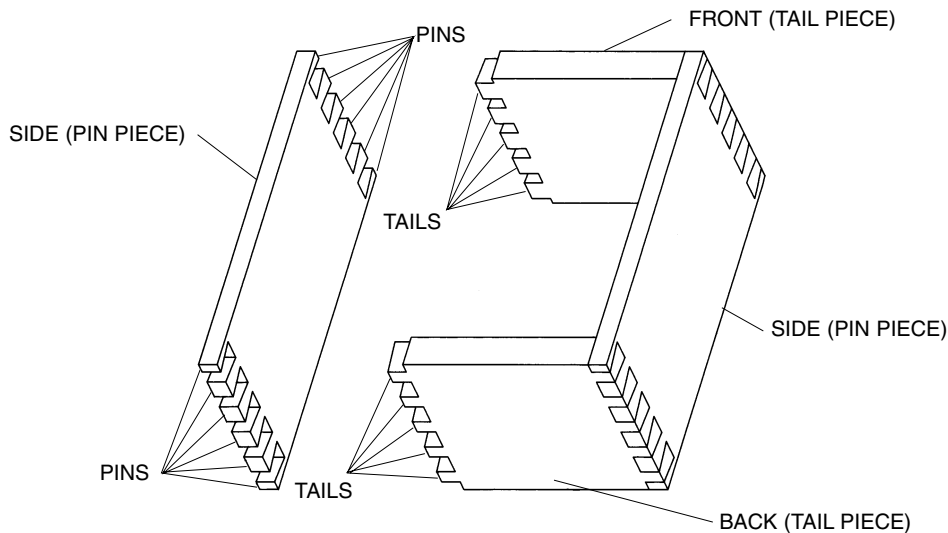

NOTE: THE DEPTH OF CUT IS DETERMINED BY THE THICKNESSES OF THE FRONT, BACK AND SIDE PIECES.

- The front and back pieces (sometimes called “tail pieces”) are cut independently from the side pieces (sometimes called “pin pieces”).
- The “pin pieces” are cut first using one edge of the template and a dovetail router bit. The depth of cut is equal to the thickness of the “tail pieces”.
- The “tail pieces” are cut next using the other edge of the template and a straight router bit. The depth of cut is equal to the thickness of the “pin pieces”. Adjustments are made at this point to obtain joint fit.

ADJUSTING THE DEPTH-OF-CUT OF THE ROUTER BIT

WARNING ALWAYS MAKE SURE THAT THE ROUTER IS "TURNED OFF" AND THAT THE ELECTRICAL CORD HAS BEEN UNPLUGGED FROM THE ELECTRICAL OUTLET BEFORE ASSEMBLING OR REMOVING ROUTER BITS TO THE ROUTER.

- You will note that there are six pockets along the front surface of the dovetail base, and that they are identified by a dimensions such as 3/8, 1/2,–up to 1. These pockets are used to set the depth-of-cut of a router bit.

To use proceed as follows:

- DO NOT USE WITH A TEMPLATE ASSEMBLED TO THE BASE.
 - DO NOT INSTALL ROUTER BITS TO THE ROUTER UNLESS THE CORRECT GUIDE BUSHING HAS BEEN ASSEMBLED TO THE BASEPLATE FIRST.
1. Install the desired router bit to the router as explained in your Router Owner's Manual. See Figure 41. A MINIMUM ROUTER BIT SHANK ENGAGEMENT OF 3/4" IS REQUIRED IN THE COLLET OF THE ROUTER.
 2. TIGHTEN THE COLLET NUT SECURELY.
 3. Position the router over the pocket with the required depth-of-cut.

CAUTION

MAKE SURE THAT THE ROUTER BIT IS ALIGNED WITH OR CENTERED IN THE HOLE IN THE GUIDE BUSHING. TO DO THIS, LOOSEN SCREWS HOLDING BASE OR ADAPTER PLATE TO ROUTER, CENTER GUIDE BUSHING HOLE WITH RESPECT TO ROUTER BIT AND RETIGHTEN SCREWS SECURELY.

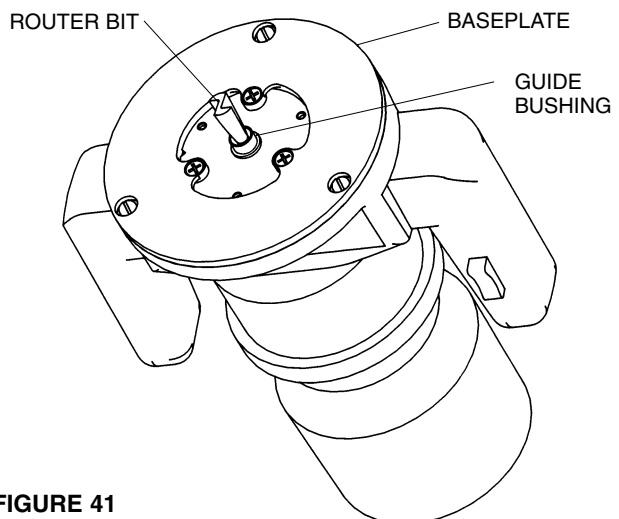

FIGURE 41

4. Gradually move the router bit outward, by using the depth-of-cut feature on the router, until the tip of the router bit touches the bottom of the pocket, as shown in Figure 42 and Figure 42A.
5. Lock the router in position.
6. The desired depth-of-cut has been set.
7. To set a depth-of-cut NOT provided for on the dovetail base, simply place the unused template on the router baseplate, as shown in Figure 43. The height from the baseplate to the end or tip of the router bit will then be the required depth of cut.

CAUTION WHEN SETTING THE DEPTH OF CUT, MAKE ABSOLUTELY SURE THAT THE COLLET NUT DOES NOT CONTACT (TOUCH) THE GUIDE BUSHING. THIS CAN CAUSE THE GUIDE BUSHING TO HEAT UP EXCESSIVELY DURING CUTTING WHICH CAN CAUSE DAMAGE TO THE TEMPLATE. TO CORRECT THIS SITUATION OR PREVENT IT FROM OCCURRING REPOSITION THE ROUTER BIT IN THE ROUTER.

FIGURE 42

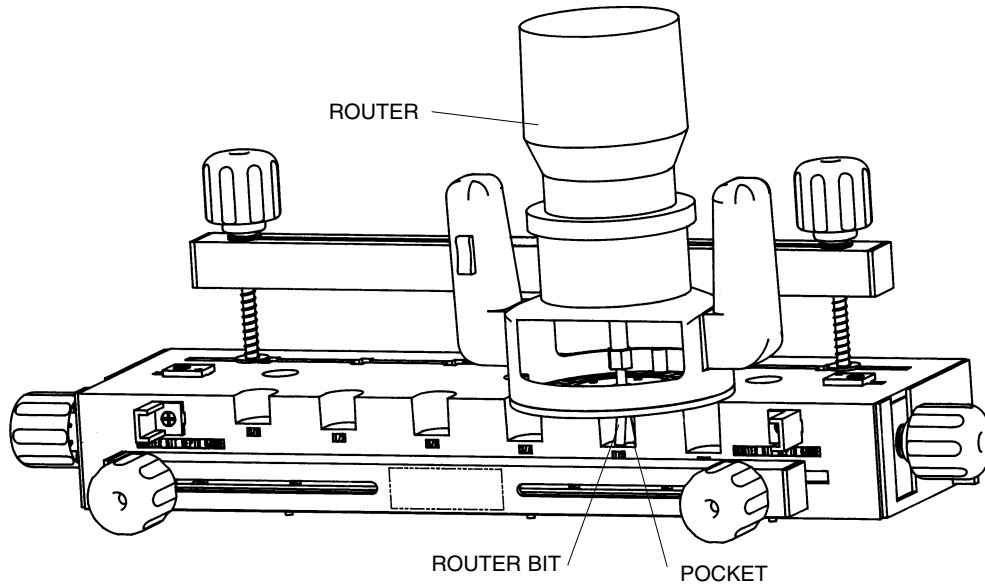

FIGURE 42A

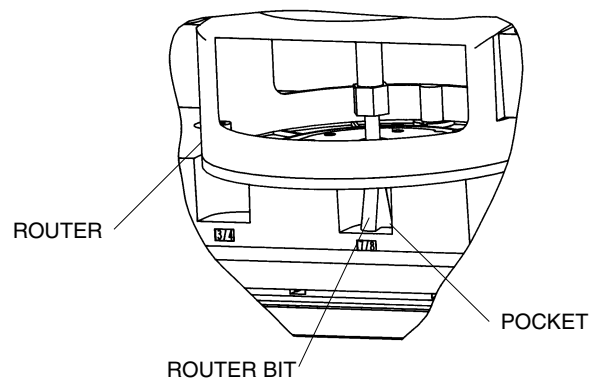
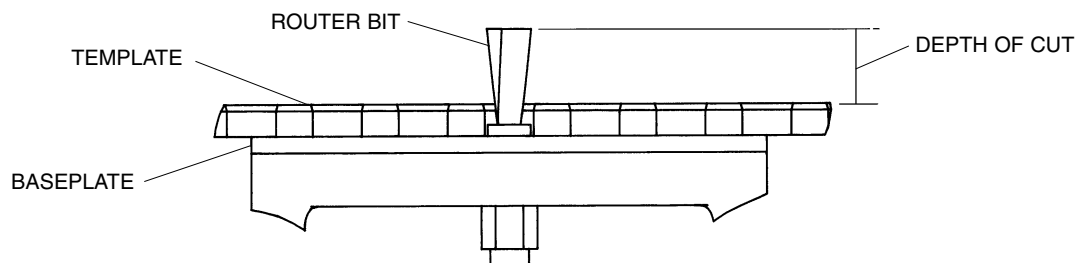

FIGURE 43



CLAMPING THE WORKPIECES TO THE DOVETAIL BASE

- The clamping bars have been specially designed to allow the clamping forces to be applied next to the workpieces for more efficient clamping. This is accomplished by being able to position the clamping knobs in close proximity or next to the workpieces.
- Figure 44 illustrates the positioning of the clamping bars and the clamping knobs when the workpieces are clamped to the LEFT SIDE of the Dovetail Jig.
- Figure 45 illustrates the positioning of the clamping bars and the clamping knobs when the workpieces are clamped to the RIGHT SIDE of the Dovetail Jig.
- Note the closeness of the clamping knobs to the workpieces. When not in use clamping knobs and the support-

ing bolts and springs are free to be moved along the slots in the base.

- CAUTION: WHEN CLAMPING, MAKE SURE THAT THE CLAMPING KNOBS ARE NOT POSITIONED SO CLOSE TO THE WORKPIECES THAT THE WASHERS BECOME TRAPPED UNDER THE WORKPIECES.
- FOR ACCURATE JOINTS, THE WORKPIECES MUST "BUTT-UP" AGAINST BOTH THE TOP AND THE FRONT STOP BLOCKS TO ENSURE THE EXACT POSITIONING OF THE WORKPIECES.
- TO ENSURE ACCURATE JOINTS AND SAFE OPERATION, WOOD SHAVINGS AND ACCUMULATED DUST MUST BE REMOVED FROM THE DOVETAIL JIG BEFORE EACH SETUP, EITHER BY USING A BRUSH OR BY VACUUMING.

FIGURE 44

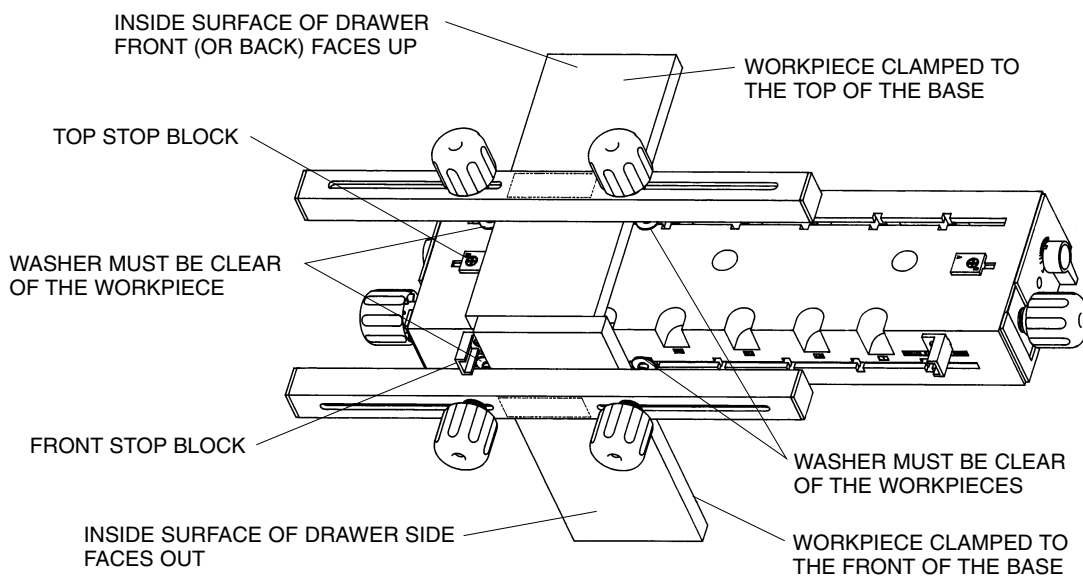
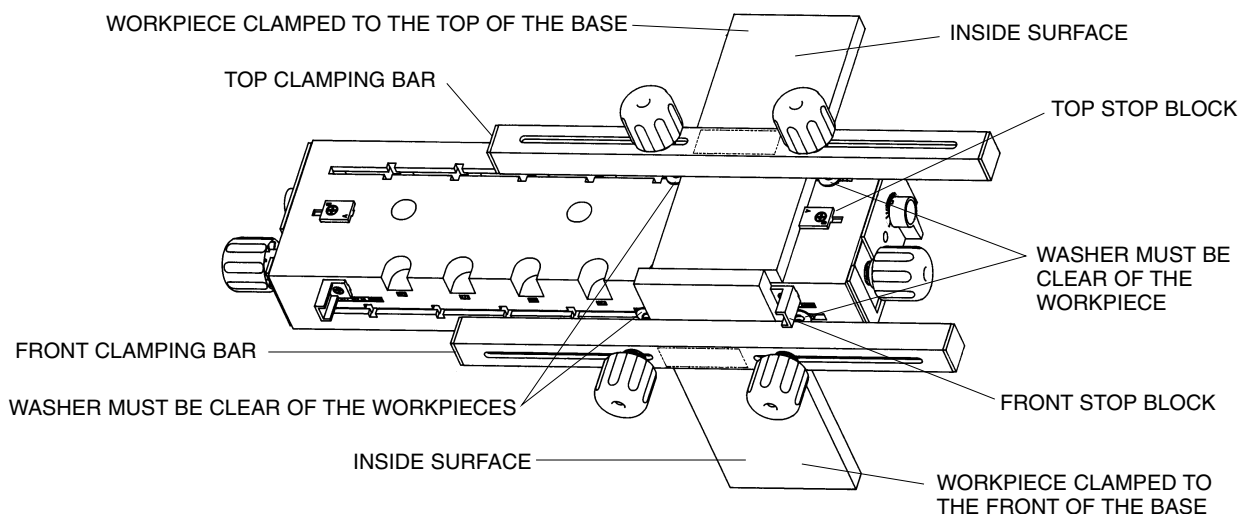

FIGURE 45



MAKING DRAWERS WITH HALF BLIND FLUSH JOINTS

- The thickness of both the front and back (**pin pieces**) must be at least 1/2". The thickness of the sides (**tail pieces**) must be at least 3/8".
- A partial tail will be cut for side (tail piece) thicknesses up to 9/16". This is normal and will not affect the joint or its appearance.
- Figure 46 shows a drawer and the workpieces that make it up. This figure is similar to Figure 38, except that it

shows the workpieces unassembled (or an exploded view of the drawer).

- In addition, the figure shows where the four corners of the drawer are cut on the Dovetail Jig. CORNERS 1 AND 3 are cut on the LEFT SIDE of the Dovetail Jig. CORNERS 2 AND 4 are cut on the RIGHT SIDE of the Dovetail Jig.
- Trial cuts are strongly recommended using scrap wood to ensure that the final workpieces are of the desired quality.

FIGURE 46

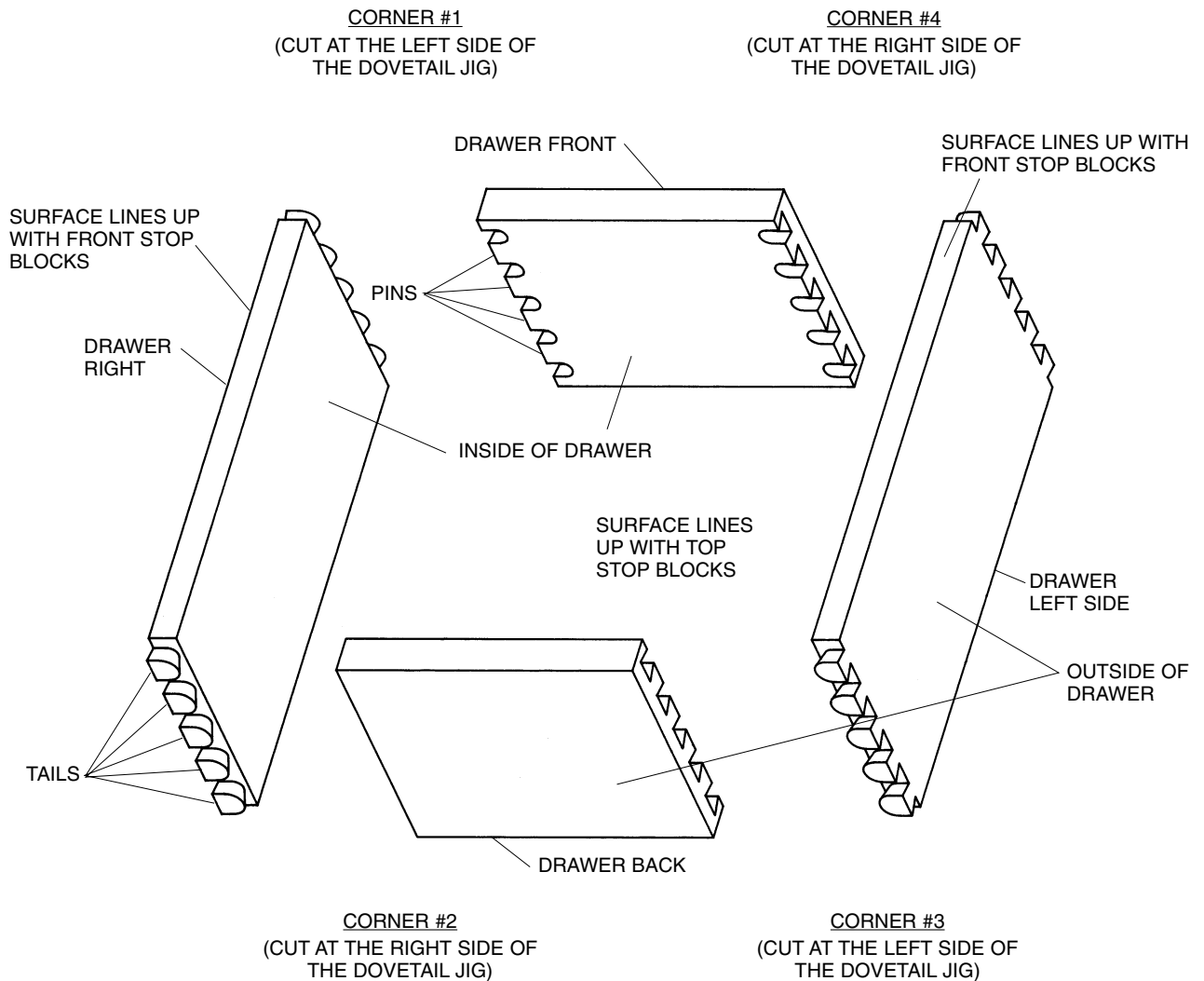

GENERAL PREPARATIONS

- a. The workpieces comprising the drawer, that is, front, back, left side, and right side should be cut to the proper length, width, and thickness(es).
- b. Make sure that all surfaces are smooth and square with each of the other surfaces.
- c. Line up the workpieces on a flat surface, standing on edge, as shown in Figure 47.
- d. With a soft lead pencil mark the front, back, left side, and right side, as shown in Figure 47. This is to aid you in

- e. positioning the workpieces on the Dovetail Jig, prior to cutting the dovetails.
- e. Assemble the .40" guide bushing to the router base-plate, as described in a previous section. This the smaller of the two guide bushings furnished with this product.
- f. Install Vermont American #22500 or Magna #M91113 dovetail router bit, to the router as described in your Router Owner's Manual. Shank engagement should be a minimum of 3/4".

FIGURE 47

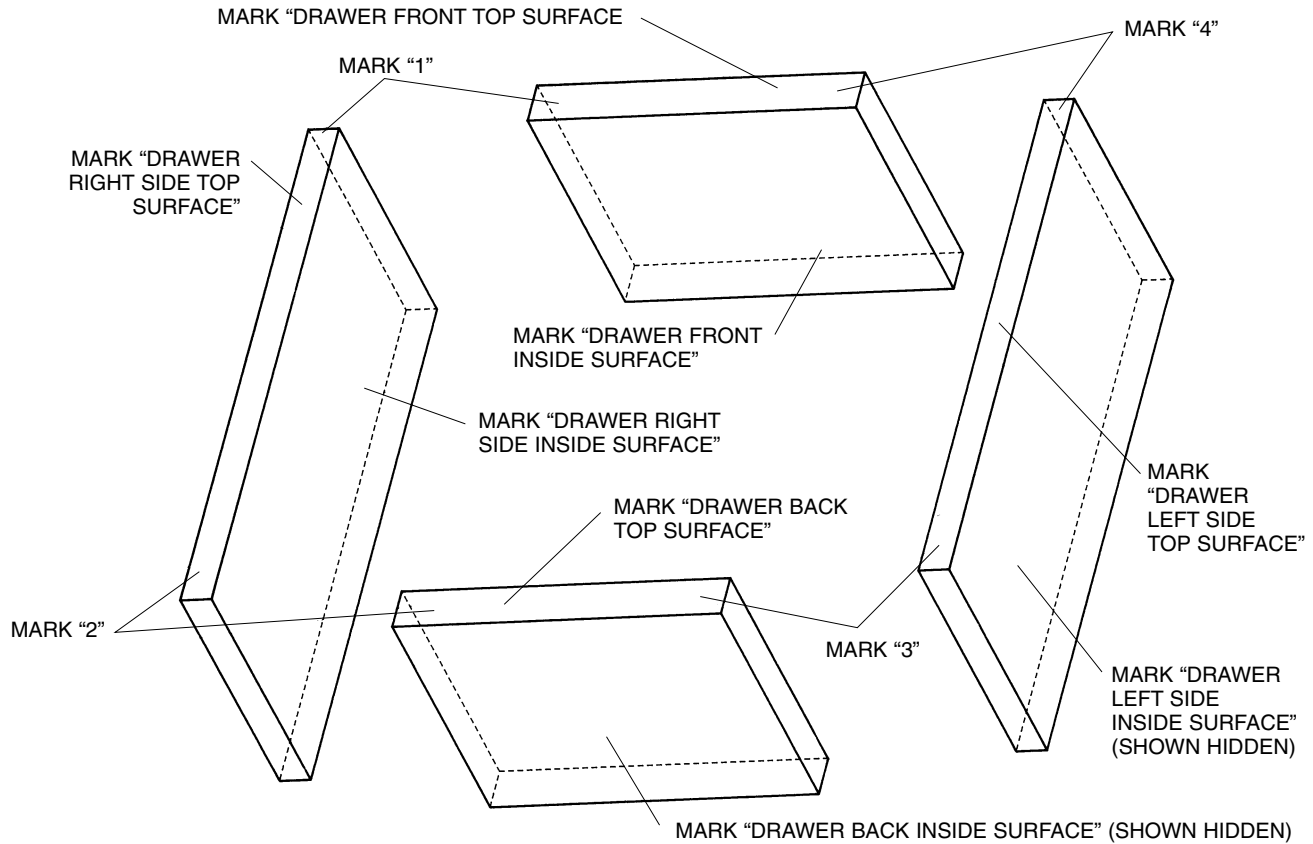

CAUTION MAKE SURE THAT THE ROUTER BIT IS ALIGNED WITH OR CENTERED IN THE HOLE IN THE GUIDE BUSHING. TO DO THIS, LOOSEN SCREWS HOLDING BASE PLATE OR ADAPTER PLATE TO ROUTER, CENTER GUIDE BUSHING HOLE WITH RESPECT TO ROUTER BIT AND RETIGHTEN SCREWS SECURELY.

CAUTION WHEN SETTING THE DEPTH OF CUT, MAKE ABSOLUTELY SURE THAT THE COLLET NUT DOES NOT CONTACT (TOUCH) THE GUIDE BUSHING. THIS CAN CAUSE THE GUIDE BUSHING TO HEAT UP EXCESSIVELY DURING CUTTING WHICH CAN CAUSE DAMAGE TO THE TEMPLATE. TO CORRECT THIS SITUATION OR PREVENT IT FROM OCCURRING, REPOSITION THE ROUTER BIT IN THE ROUTER.

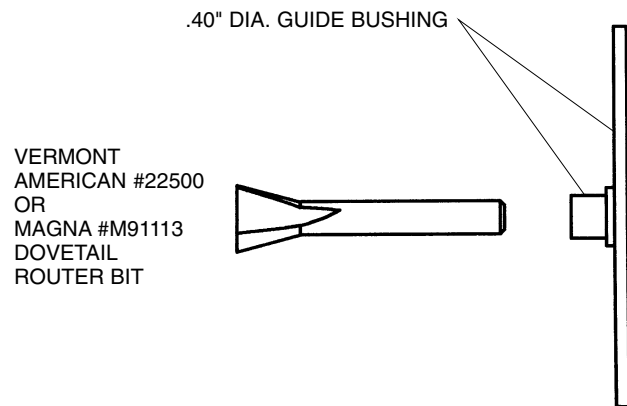

g. Adjust the depth of cut to 3/8" using the depth gauge on the base of the Dovetail Jig, as described in a previous section. This setting is approximate and some adjustment may be required.

h. Position both of the top stop blocks so that the "A" faces the "middle of the base" as shown in Figure 48.
i. Position the cam handle so that the pointer points to the center graduation as shown in Figure 48.

FIGURE 48

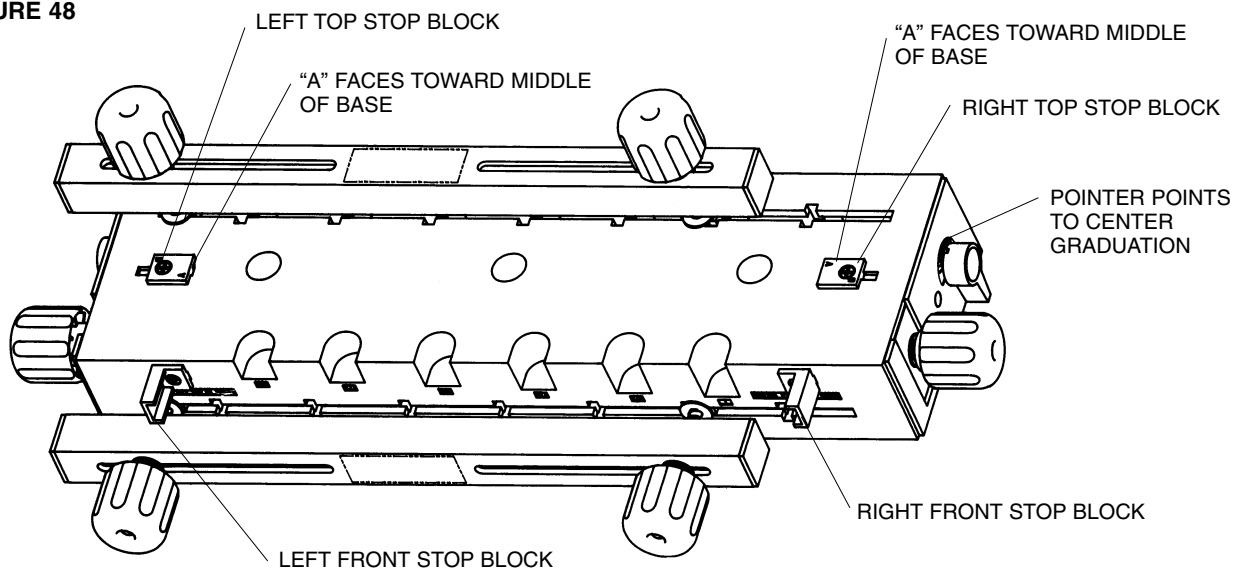

THE FOLLOWING DESCRIBES THE PROCEDURE TO BE FOLLOWED FOR CUTTING CORNERS 1 AND 3

1. FOR CORNER #1, position the drawer front on the top of the base so that it lines up with the front of the base and the top surface abuts the left top stop block. THE INSIDE OF THE DRAWER FRONT FACES AWAY FROM THE TOP OF THE BASE. The words "INSIDE SURFACE" marked in (d) in the Section, GENERAL PREPARATIONS, should be visible.
2. Lightly clamp the drawer front in place.
3. Position the drawer RIGHT side against the front of the

- base so that the top surface abuts the left front stop block. THE INSIDE OF THE DRAWER SIDE FACES AWAY FROM THE FRONT OF THE BASE. The words "INSIDE SURFACE" marked in (d) in the Section, GENERAL PREPARATIONS, should be visible.
4. Line up the workpieces so that the end of the drawer side lines up with the drawer front as shown in Figure 49.
5. Securely clamp the drawer side to the base.
6. Securely clamp the drawer front to the base.
7. Make sure that the parts remain lined up.

FIGURE 49

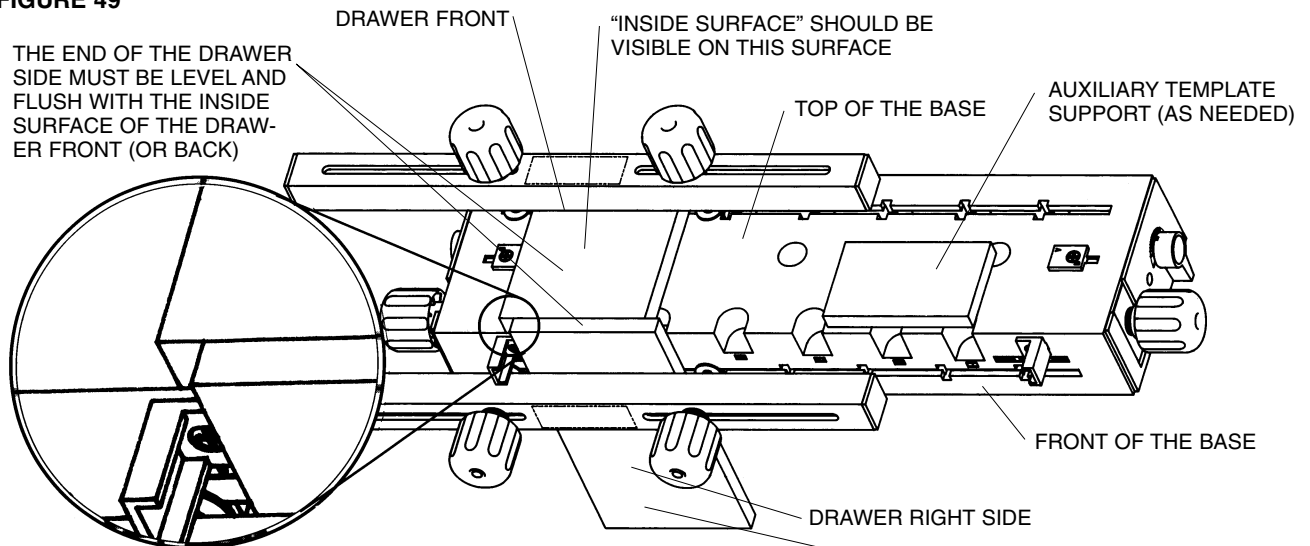

NOTE: WORKPIECES WILL BE POSITIONED ON THE JIG AS

"INSIDE SURFACE" SHOULD BE VISIBLE ON THIS SURFACE

FIGURE 50

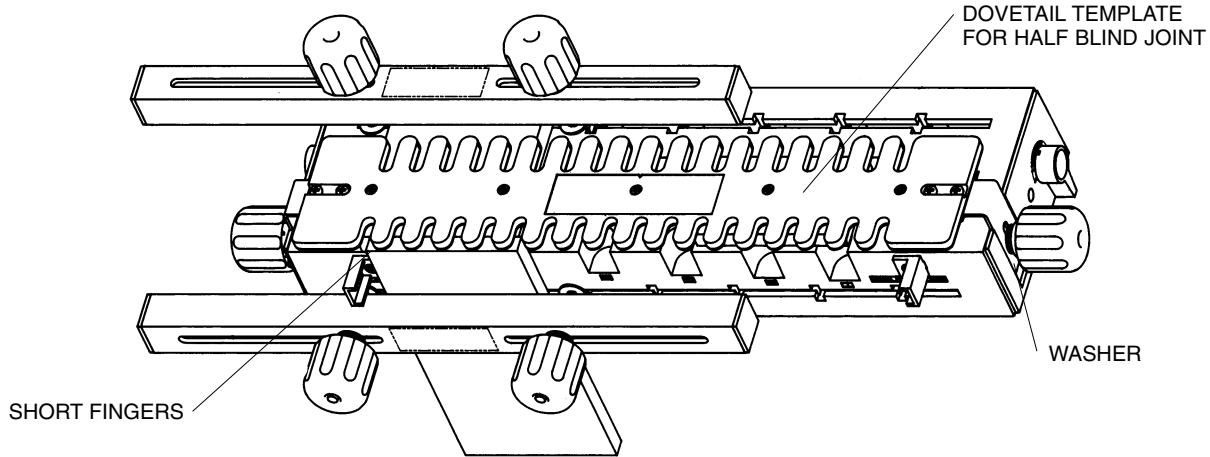

8. Assemble the DOVETAIL TEMPLATE FOR HALF BLIND JOINTS to the Dovetail Jig so that THE TEMPLATE BRACKETS FIT BETWEEN THE WASHERS AND THE TEMPLATE SUPPORTS as shown Figure 50.

NOTE: MAKE SURE THE TEMPLATE CLAMPING KNOBS ARE LOOSE TO MAKE TEMPLATE ADJUSTMENT. AFTER ADJUSTMENT IS MADE, RETIGHTEN TEMPLATE CLAMPING KNOBS.

9. Make sure that the short fingers on the template, as shown in Figure 50, faces toward the front of the base.

10. Make sure that the template is flush and parallel with the workpieces clamped to base. For narrow drawer fronts, the use of an auxiliary support for the template is recommended. Its purpose is to aid in supporting the router while cutting. It can be made from a piece of scrap wood; but its thickness must be the same as the drawer front. (Refer to Figure 49.)

11. Clamp the template in place by tightening the clamping knobs.

12. **WARNING** BEFORE MAKING ANY CUTS MAKE SURE THAT THE BIT WILL NOT CUT INTO THE BASE OR ANY OTHER COMPONENT OF THE DOVETAIL JIG. THIS CAN CAUSE DAMAGE TO THE DOVETAIL JIG; OR LOSS OF CONTROL OF THE ROUTER WHICH CAN RESULT IN SERIOUS BODILY INJURY. A TRIAL RUN WITH THE ROUTER TURNED OFF AND UNPLUGGED FROM THE ELECTRICAL OUTLET IS STRONGLY RECOMMENDED.

13. TURN THE ROUTER ON.

14. Cut the dovetail by moving the router from LEFT TO RIGHT, with the guide bushing following the template. DO NOT FORCE ANYTHING; MOVE THE ROUTER IN SLOW AND SMOOTH FASHION.

15. To ensure a smooth and uniform joint, retrace the previous cut by moving the router from RIGHT TO LEFT with the guide bushing again following the template.

16. **WARNING** NEVER LIFT THE ROUTER UPWARDS WHEN THE ROUTER IS ON AND THE ROUTER BIT ROTATING OR WHEN THE GUIDE BUSHING IS NEAR TO OR TOUCHING THE TEMPLATE. THIS CAN CAUSE DAMAGE TO THE DOVETAIL JIG; OR LOSS OF CONTROL OF THE ROUTER WHICH CAN RESULT IN SERIOUS BODILY INJURY.

17. After the cut has been made, the workpieces should look like those illustrated in Figure 51.

FIGURE 51

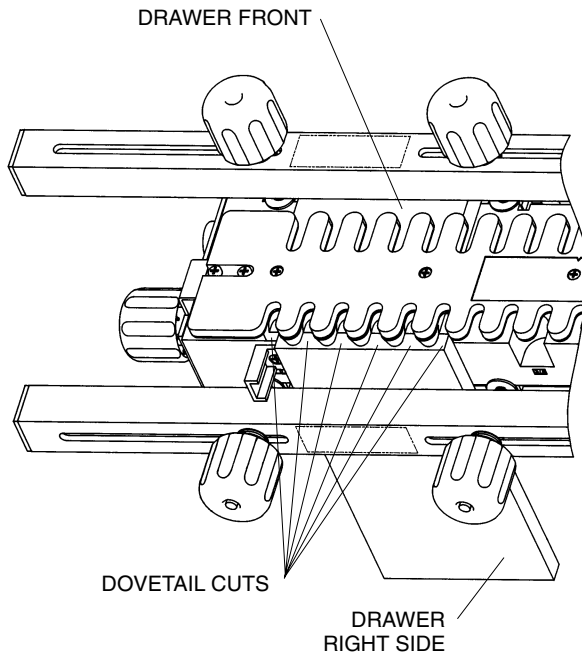

18. Remove the workpieces from the Dovetail Jig and check how the workpieces fit together. Some adjustments may be required. Refer to the section TROUBLESHOOTING on page 37.

19. FOR CORNER #3, position the drawer back on the top of the base so that it lines up with the front of the base and the top edge surface abuts the left top stop block. THE INSIDE OF THE DRAWER BACK FACES UP. The words "INSIDE SURFACE" marked in (d) in the Section, GENERAL PREPARATIONS, should be visible. See Figure 52.

20. Lightly clamp the drawer back in place.

21. Position the drawer LEFT side against the front of the base so that the top surface abuts the left front stop block.

THE INSIDE OF THE DRAWER SIDE FACES UP. The words "INSIDE SURFACE" marked in (d) in the Section, GENERAL PREPARATIONS, should be visible

22. Line up the workpieces so that the end of the drawer side lines up with the drawer back as shown in Figure 52.

23. Continue as in Steps 5 through 16 above.

24. After the cut has been made, the workpieces should look like those illustrated in Figure 53.

25. Remove the workpieces from the Dovetail Jig and check how the workpieces fit together. Some adjustments may be required. Refer to the section TROUBLESHOOTING on page 37.

FIGURE 52

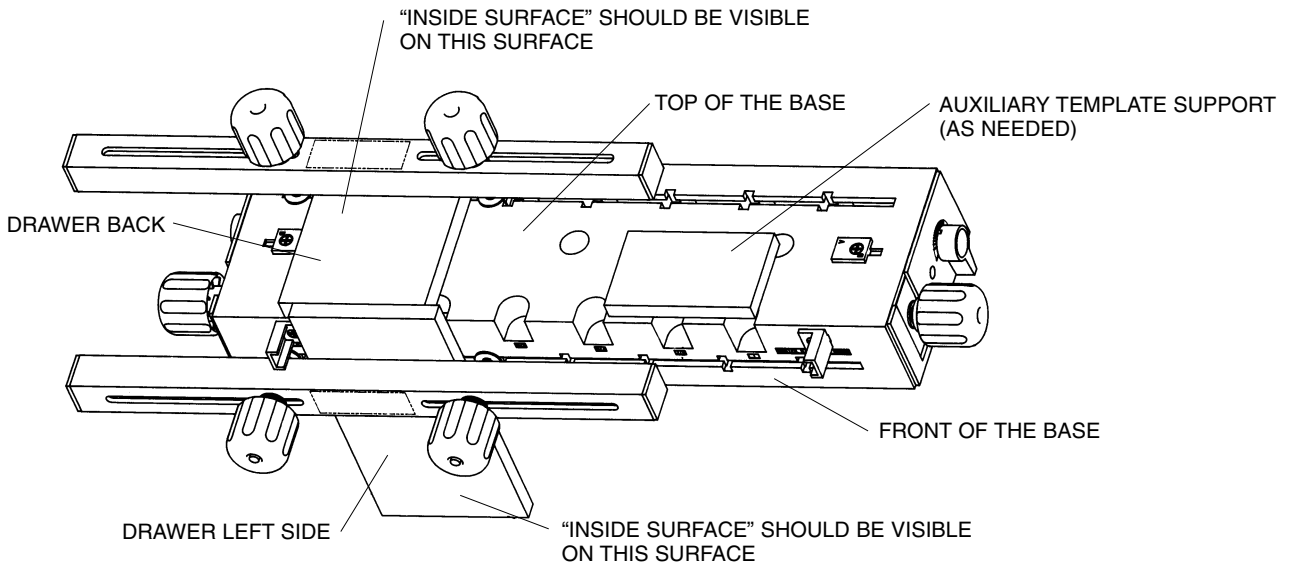
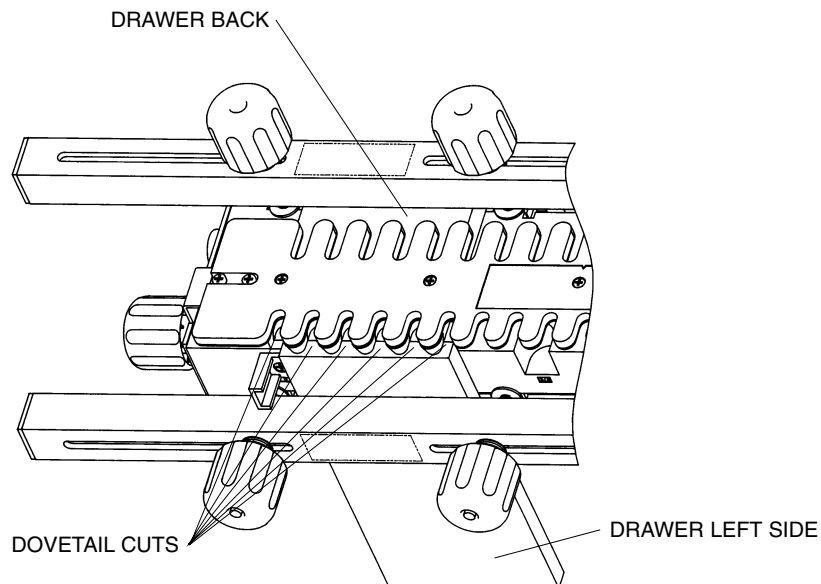

FIGURE 53



THE FOLLOWING DESCRIBES THE PROCEDURE TO BE FOLLOWED FOR CUTTING CORNERS 2 AND 4

CORNERS 2 AND 4 are cut in the same way as 1 and 3 except they are positioned on the right side of the Dovetail Jig as shown Figure 54.

• **CAUTION** BEFORE MAKING ANY CUTS MAKE SURE THAT THE BIT WILL NOT CUT INTO THE BASE OR ANY OTHER COMPONENT OF THE DOVETAIL JIG. THIS CAN CAUSE DAMAGE TO THE DOVETAIL JIG.

• **CAUTION** NEVER LIFT THE ROUTER UPWARDS WHEN THE ROUTER IS ON AND THE ROUTER BIT ROTATING OR WHEN THE GUIDE BUSHING IS NEAR TO OR TOUCHING THE TEMPLATE. THIS CAN CAUSE DAMAGE TO THE DOVETAIL JIG.

- After the cut has been made, the workpieces should look like those illustrated in Figure 53.
- The finished front, back, and sides should look like those in Figure 46.
- **Before gluing the front, back, and sides together, some provision must be made for installing the bottom, such as dadoing or cutting a groove around the inside of the drawer parts.**
- Your drawer is now ready to be glued together.

FIGURE 54

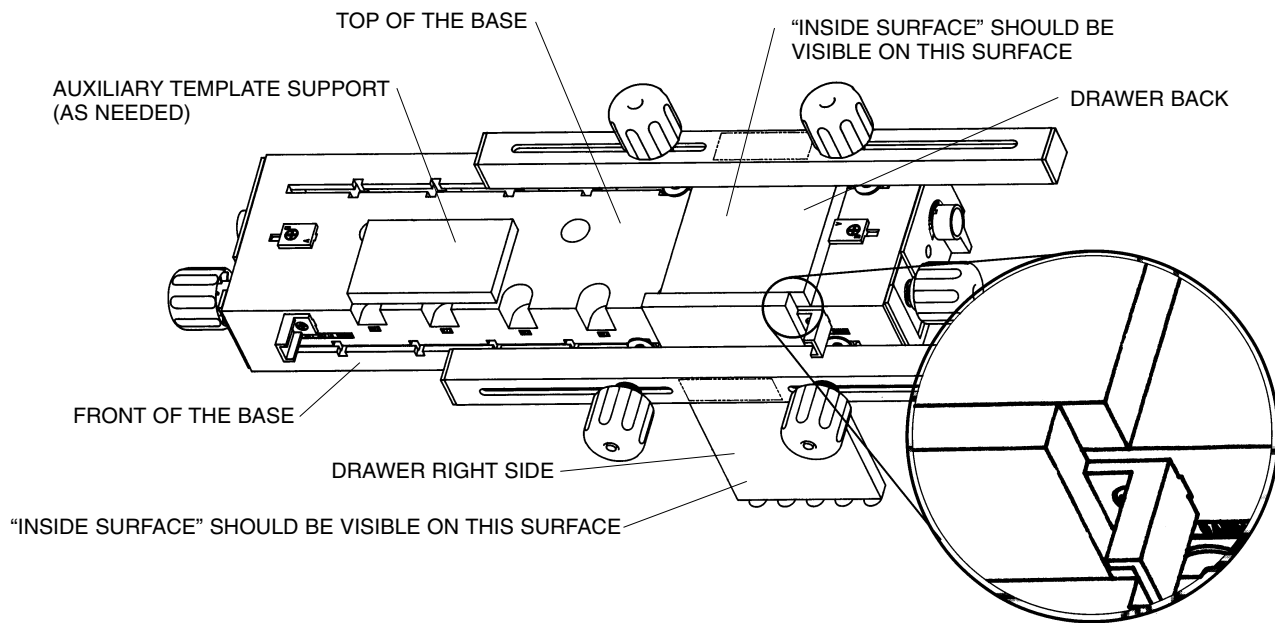

NOTE: WORKPIECES WILL BE POSITIONED ON THE JIG AS

MAKING DRAWERS WITH HALF BLIND FLUSH OFFSET JOINTS

GENERAL PREPARATIONS

- The length of the drawer front is 1/8" longer than the length of the drawer back.
- When cutting corners 1 and 4; the cam handle is rotated two graduations toward the back of the base, thus moving the template 1/32" toward the back of the base. (Refer to Figure 55).

NOTE: MAKE SURE THE TEMPLATE CLAMPING KNOBS ARE LOOSE TO MAKE TEMPLATE ADJUSTMENT. AFTER ADJUSTMENT IS MADE, RETIGHTEN TEMPLATE CLAMPING KNOBS.

- When cutting corners 2 and 3; the cam handle is positioned vertically, as shown in Figure 48.
- All other GENERAL PREPARATIONS are the same as those used for "MAKING DRAWERS WITH HALF BLIND FLUSH JOINTS".

THE PROCEDURE FOR CUTTING THESE JOINTS IS THE SAME AS THAT USED FOR "MAKING DRAWERS WITH HALF BLIND FLUSH JOINTS".

- After all dovetail cuts have been made, cut a 1/16" deep by 3/8" deep rabbet on opposite ends of the drawer front.
- The finished front, back, and sides should look like those in Figure 38.
- Before gluing the front, back, and sides together, some provision must be made for installing the bottom, such

FIGURE 55

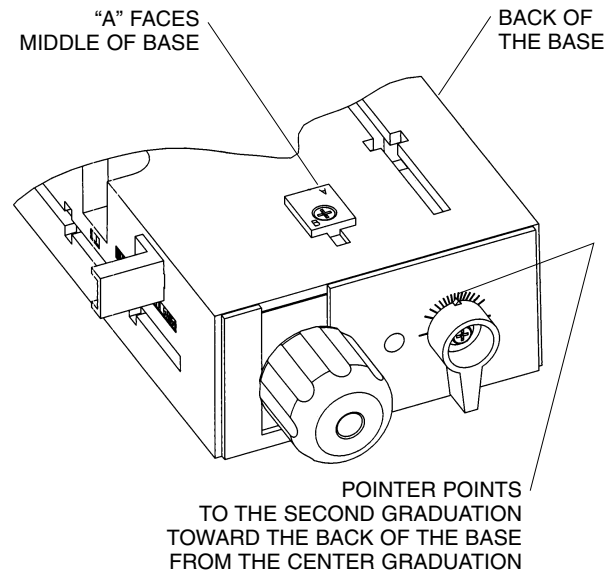

as dadoing or cutting a groove around the inside of the drawer parts.

- Your drawer is now ready to be glued together.
- Remove the pencil markings by light sanding or with a soft eraser after the drawer parts have been glued together.

MAKING DRAWERS WITH HALF BLIND RABBETED JOINTS

GENERAL PREPARATIONS

- The length of the drawer front is $\frac{3}{4}$ " longer than the length of the drawer back.
 - The height of the drawer front is $\frac{3}{4}$ " higher than the height of the drawer back and drawer sides.
- IT IS EXTREMELY IMPORTANT THAT THE TEMPLATE BE PROPERLY ALIGNED WHEN MAKING THESE JOINTS, OR ELSE, IN ADDITION TO THE JOINT SPACING NOT BEING EQUAL, AS SHOWN IN FIGURE 60 BELOW, THE TOP SURFACES OF THE SIDES, FRONT, AND BACK WILL NOT "LINE-UP" PROPERLY EITHER. REFER TO THE SECTION "ALIGNMENT OF THE TEMPLATES." (Figure 60 illustrates a Flush Dovetail Joint.)
 - All other GENERAL PREPARATIONS, **except as noted below in the procedure**, are the same as those used for "MAKING DRAWERS WITH HALF BLIND FLUSH JOINTS".

THE PROCEDURE FOR CUTTING CORNERS 1 AND 4 IS THE SAME AS THAT USED FOR "MAKING DRAWERS WITH HALF BLIND FLUSH JOINTS" EXCEPT

- Position BOTH top stop blocks so that the "B" faces the middle of the base as shown in Figure 56.
- Use the side of the template that has the longest fingers.
- Position the template and workpieces as shown in Figure 57. Cut the dovetail as described in the section, MAKING DRAWERS WITH HALF BLIND FLUSH JOINTS.
- Before gluing the front, back, and sides together, some provision must be made for installing the bottom, such as dadoing or cutting a groove around the inside of the drawer parts.**
- Your drawer is now ready to be glued together.
- Remove the pencil markings by light sanding or with a soft eraser after the drawer parts have been glued together.

FIGURE 56

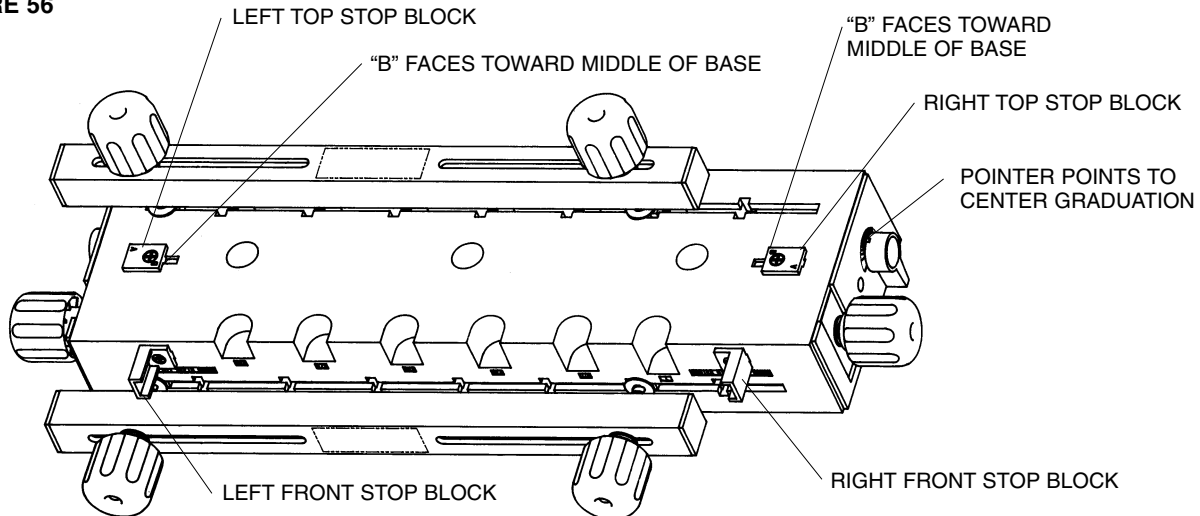
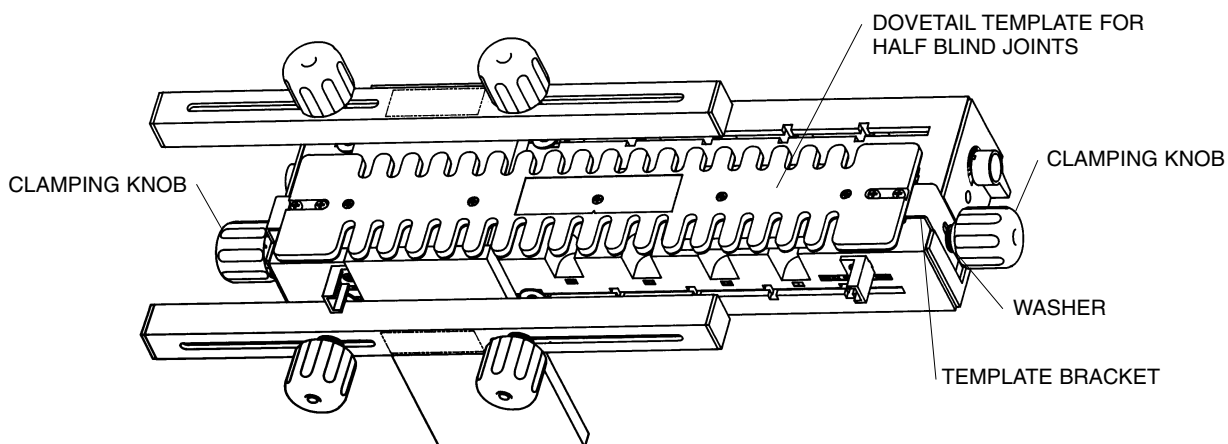

FIGURE 57



TROUBLESHOOTING

- **If the joint is too loose:** INCREASE the depth of cut by INCREASING the amount by which the router bit extends beyond the baseplate by 1/64" to 1/32" and make a trial cut. Continue adjusting until desired joint fit is attained.
- **If the joint is too tight:** DECREASE the depth of cut by DECREASING the amount by which the router bit extends beyond the baseplate by 1/64" to 1/32" and make a trial cut. Continue adjusting until desired joint fit is attained.
- **If the joint is too shallow:** Refer to Figure 58. Loosen the clamping knobs holding the template brackets and move the template INWARD half the additional depth needed by turning the cam handles. Retighten the clamping knobs.
- **If the joint is too deep:** Refer to Figure 59. Loosen the clamping knobs holding the template brackets and move the template OUTWARD by turning the cam handles half the distance needed. Retighten the clamping knobs.
- **If the joint is not uniformly spaced from top surface of drawer:** Refer to Figure 60. (See the Section "ALIGNMENT OF THE TEMPLATES".) With the template clamped to the base, loosen the four screws securing the template to the template brackets, and move the template slightly to the left. Tighten the four screws and make a trial cut. If moving the template to the left did not correct the condition, but made it worse, loosen the screws and move the template to the right a small amount. Tighten the four screws and make a trial cut. Continue moving the template to the right until the condition is completely corrected. **MAKE SURE TO SECURELY TIGHTEN THE FOUR SCREWS.** If moving the template to the left improves the condition, continue moving the template to the left until the condition is completely corrected. Make sure the template remains parallel to the front of the dovetail base. **MAKE SURE TO SECURELY TIGHTEN THE FOUR SCREWS.** AFTER THE TEMPLATES HAVE BEEN CORRECTLY REALIGNED, THEY SHOULD REQUIRE NO FURTHER ADJUSTMENTS IF THEY ARE HANDLED WITH CARE.

FIGURE 58 – JOINT IS TOO SHALLOW

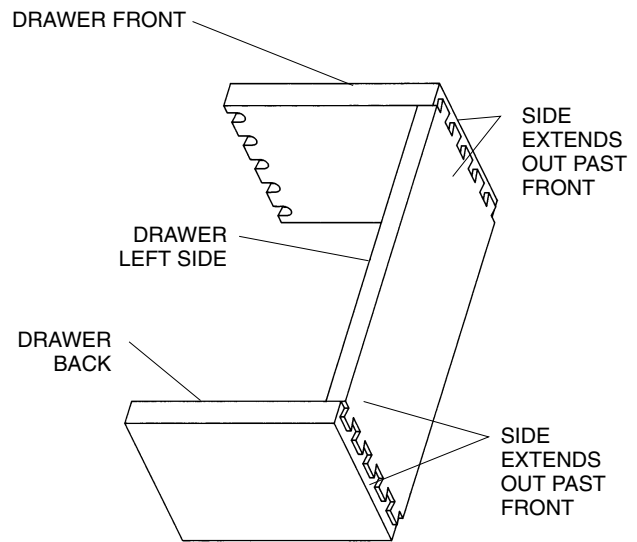

FIGURE 59 – JOINT IS TOO DEEP

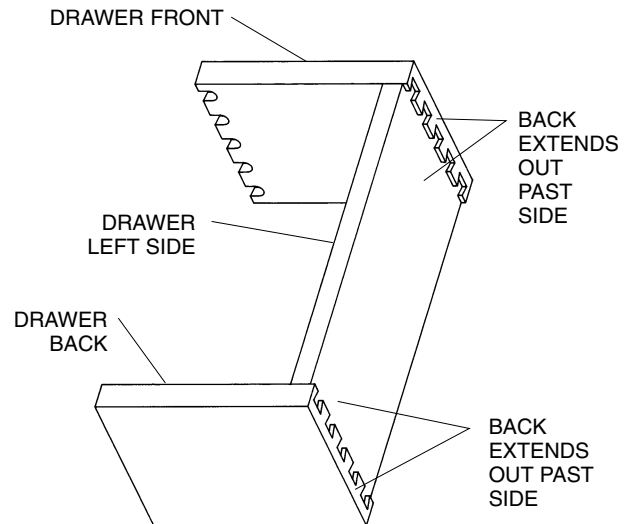
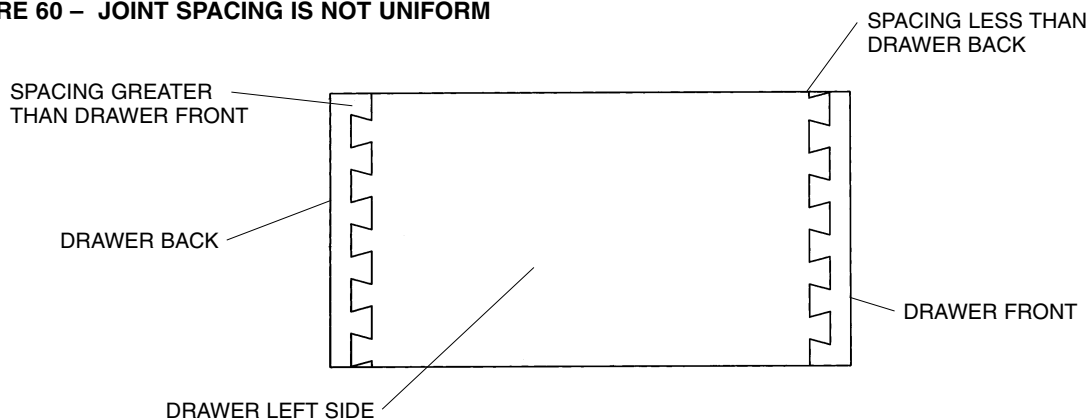

FIGURE 60 – JOINT SPACING IS NOT UNIFORM



MAKING PROJECTS WITH OPEN (THROUGH) JOINTS

- The thickness of both the front and the back (tail pieces) must be between 3/8" and 1".
- The thickness of the sides (pin pieces) must also be between 3/8" and 1".
- Figure 61 shows a project and the workpieces that make it up. This figure is similar to Figure 40, except that it shows the workpieces unassembled.
- Trial cuts are strongly recommended using scrap wood to ensure that the final workpieces are of the desired quality.

GENERAL PREPARATIONS

- The workpieces comprising the project, that is, front, back, left side and right side should be cut to the proper length, width and thickness(es).
- Make sure that all surfaces are smooth and square with each of the other surfaces.
- Line up the workpieces on a flat surface, standing on edge, as shown in Figure 62.
- With a soft lead pencil mark the front, back and two sides, as shown in Figure 62, also. This is to aid you in positioning the workpieces on the Dovetail Jig, prior to cutting the dovetails.**
- Position both of the top stop blocks so that the "A" faces the "middle of the base" as shown in Figure 48.
- Position the cam handle so that the pointer points to the center graduation as shown in Figure 48.

FIGURE 61

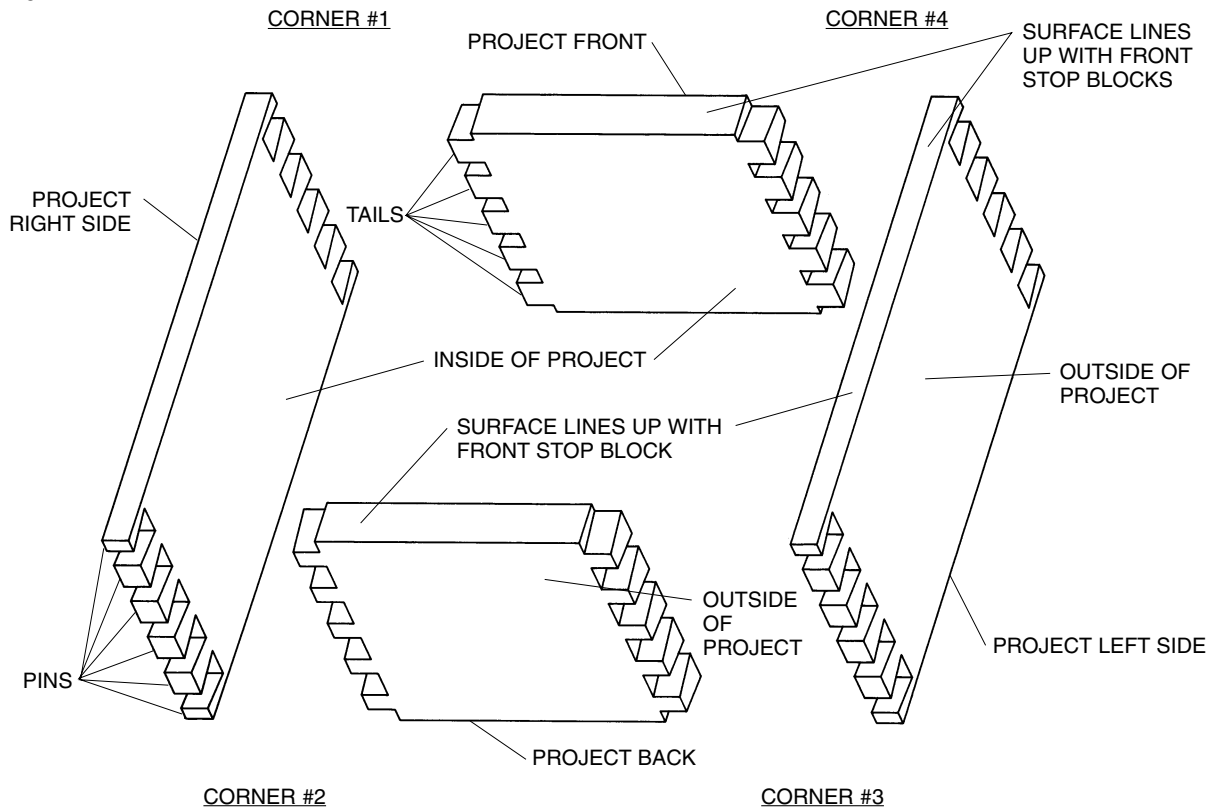
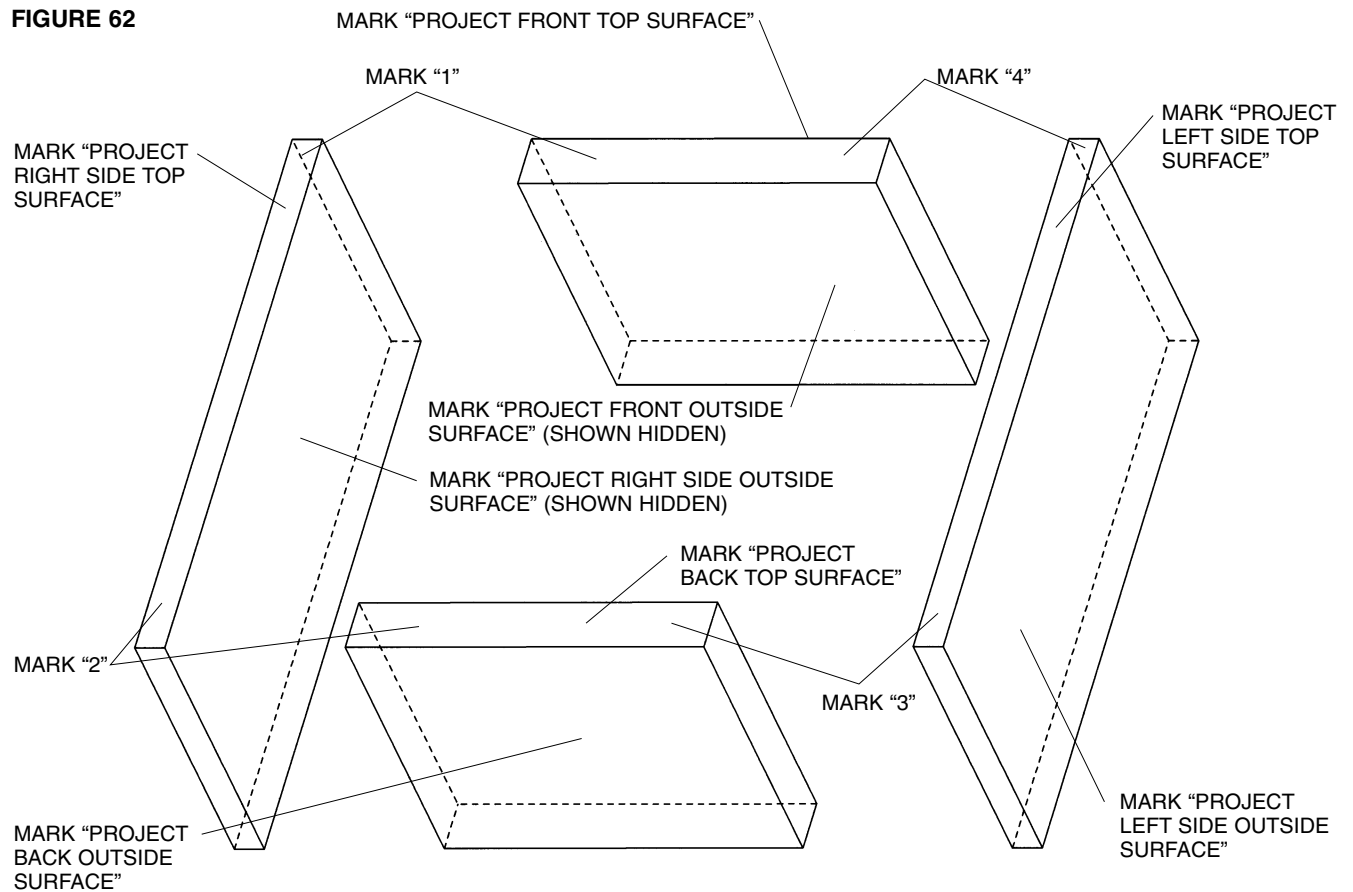

FIGURE 62



THE FOLLOWING DESCRIBES THE PROCEDURE TO BE FOLLOWED FOR CUTTING THE PROJECT RIGHT SIDE AND THE PROJECT LEFT SIDE

NOTE: THESE WORKPIECES MUST BE CUT FIRST BECAUSE ANY JOINT FIT ADJUSTMENTS THAT MAY BE REQUIRED CAN ONLY BE MADE WHEN CUTTING THE PROJECT FRONT AND PROJECT BACK—THAT IS, THE DRAWER FRONT AND THE PROJECT BACK ARE FIT TO THE SIDES.

1. Assemble the 1/2" guide bushing to the router base-plate, as described in a previous section. This is the larger of the two guide bushings furnished with this product
2. Install Vermont American #22501 or Magna #M91114, to the router as described in your Router Owners Manual. Shank engagement should be a minimum of 3/4".

CAUTION MAKE SURE THAT THE ROUTER BIT IS ALIGNED WITH OR CENTERED IN THE HOLE IN THE GUIDE BUSHING. TO DO THIS, LOOSEN SCREWS HOLDING BASE PLATE OR ADAPTER PLATE TO ROUTER, CENTER GUIDE BUSHING HOLE WITH RESPECT TO ROUTER BIT AND RETIGHTEN SCREWS SECURELY.

CAUTION WHEN SETTING THE DEPTH OF CUT, MAKE ABSOLUTELY SURE THAT THE COLLET NUT DOES NOT CONTACT (TOUCH) THE GUIDE BUSHING. THIS CAN CAUSE THE GUIDE BUSHING TO HEAT UP EXCESSIVELY DURING CUTTING WHICH CAN CAUSE DAMAGE TO THE TEMPLATE. TO CORRECT THIS SITUATION OR PREVENT IT FROM OCCURRING, REPOSITION THE ROUTER BIT IN THE ROUTER.

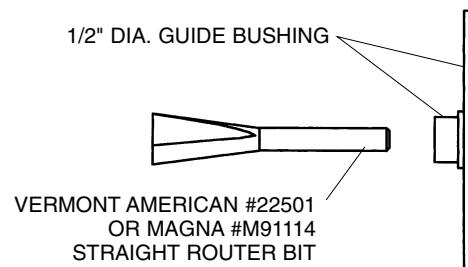

3. Adjust the depth of cut. The depth of cut for an OPEN DOVETAIL JOINT is equal to the thickness of the mating part. That is:

FOR **CORNER #1** OF THE PROJECT **RIGHT SIDE** and FOR **CORNER #4** OF THE PROJECT **LEFT SIDE**, THE DEPTH OF CUT IS EQUAL TO THE THICKNESS OF THE PROJECT **FRONT**.

FOR **CORNER #2** OF THE PROJECT **RIGHT SIDE** and FOR **CORNER #3** OF THE PROJECT **LEFT SIDE**, THE DEPTH OF CUT IS EQUAL TO THE THICKNESS OF THE PROJECT **BACK**.

Use the depth gauge on the base of the Dovetail Jig, as described in a previous section, as a starting point.

4. At this point it will be necessary for you to make a top back-up board. The reasons for the top back-up board are to minimize splintering and to provide support for the template. The top back-up board is a scrap piece of wood having the following dimensions:

- LENGTH: 6" to 8", sufficient length so that it can be clamped by the top clamping bar and be used more than once;
- WIDTH: 2" wider than the width of the project sides;
- THICKNESS: 1/8" to 1/4" thicker than the thickness of the project sides; this to prevent "ACCIDENTALLY" cutting into the dovetail base.

This can also be accomplished by using more than one piece of scrap as long as the resultant length, width and thickness are as described.

5. TO CUT CORNER #1 OF THE PROJECT RIGHT SIDE, position the top back-up board on top of the base so that it lines up with the front of the base and abuts to the right top stop block as shown in Figure 63.

NOTE: BACK-UP BOARDS ARE USED TO MINIMIZE SPLINTERING OF PROJECT PIECES AND TO KEEP ROUTER BIT FROM DAMAGING THE DOVETAIL JIG.

6. Lightly clamp the back-up board in place.
7. Position the project side against the front of the base so that the top surface abuts the right front stop block. The use of a front back-up board at this step is also recommended. It is positioned between the project side and the clamping bar as shown in Figure 63. The front back-up board should have the following approximate dimensions
 - LENGTH: 6" to 8", sufficient length so that it can be clamped by the front clamping bar and be used more than once;
 - WIDTH: 1" to 2" wider than the width of the sides;
 - THICKNESS: 1/4" to 1/2".

THE OUTSIDE OF THE PROJECT SIDE FACES AWAY FROM THE FRONT OF THE BASE

The words "OUTSIDE SURFACE" marked in (d) in the Section, GENERAL PREPARATIONS, should have been visible before the front back-up board was put in place

8. Line up the workpieces so that the end of the project side and back-up boards line up as shown in Figure 63.

9. Securely clamp the project side and the front back-up board to the front of the base.

10. Securely clamp the top back-up board to the top of the base.

11. Make sure that the parts remain lined up.

12. Assemble the DOVETAIL TEMPLATE FOR OPEN (THROUGH) JOINTS to the Dovetail Jig so that THE TEMPLATE BRACKETS FIT BETWEEN THE WASHERS AND THE TEMPLATE SUPPORTS as shown Figure 64; it will be necessary to loosen the clamping knobs at the ends of the base to do this.

FIGURE 63

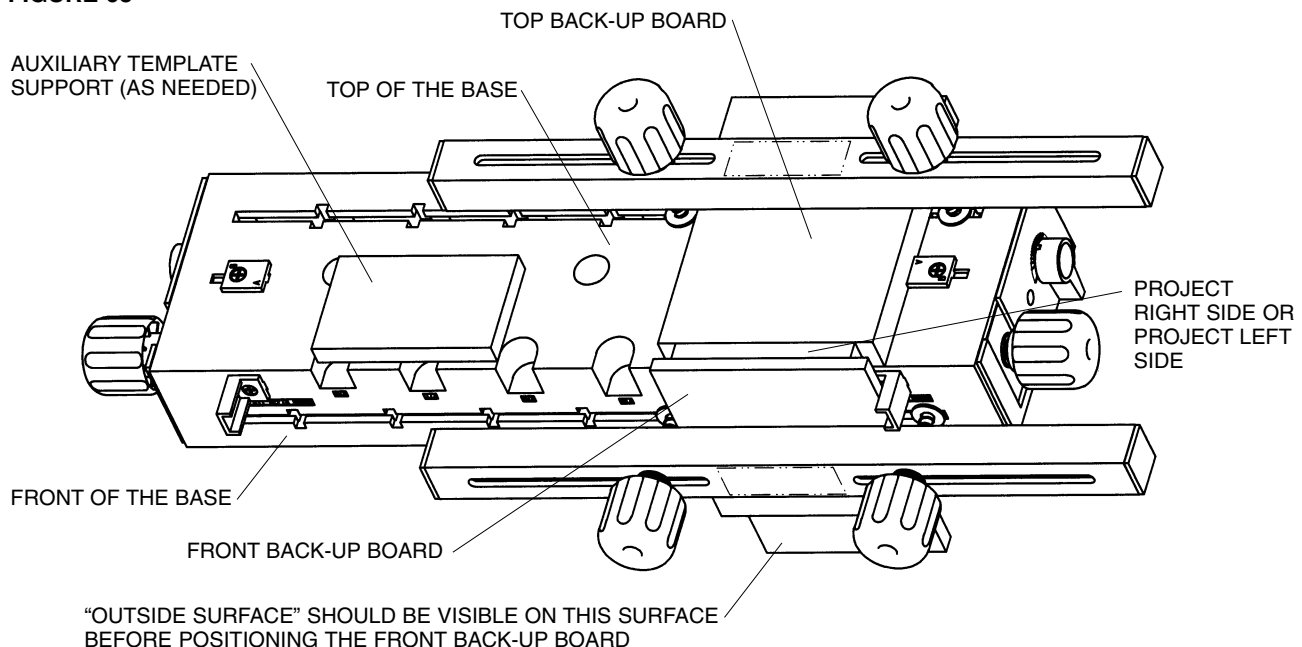

13. Make sure that the template is oriented as shown in Figure 65.

14. Make sure that the template is flush and parallel with the workpieces clamped to base. For narrow project sides, the use of an auxiliary support for the template is recommended. Its purpose is to aid in supporting the router while cutting. It can be made from a piece of scrap wood; but its thickness must be the same as the top back-up board. (Refer to Figure 63).

15. Clamp the template in place by tightening the clamping knobs.

CAUTION BEFORE MAKING ANY CUTS MAKE SURE THAT THE BIT WILL NOT CUT INTO THE BASE OR ANY OTHER COMPONENT OF THE DOVETAIL JIG.

THIS CAN CAUSE DAMAGE TO THE DOVETAIL JIG; OR LOSS OF CONTROL OF THE ROUTER WHICH CAN RESULT IN SERIOUS BODILY INJURY. A TRIAL RUN WITH THE ROUTER TURNED OFF AND UNPLUGGED FROM THE ELECTRICAL OUTLET IS STRONGLY RECOMMENDED.

16. TURN THE ROUTER ON.

17. Cut the dovetail by moving the router from LEFT TO RIGHT, with the guide bushing following the template. DO NOT FORCE ANYTHING; MOVE THE ROUTER IN SLOW AND SMOOTH FASHION.

18. To ensure a smooth and uniform joint, retrace the previous cut by moving the router from RIGHT TO LEFT with the guide bushing again following the template.

FIGURE 64

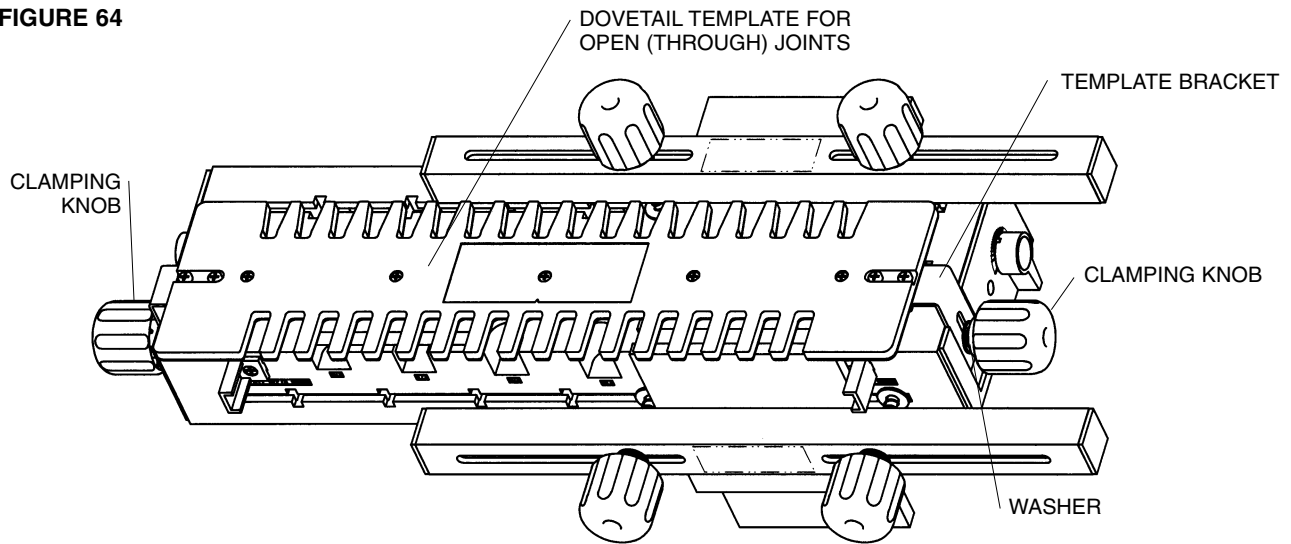

FIGURE 65

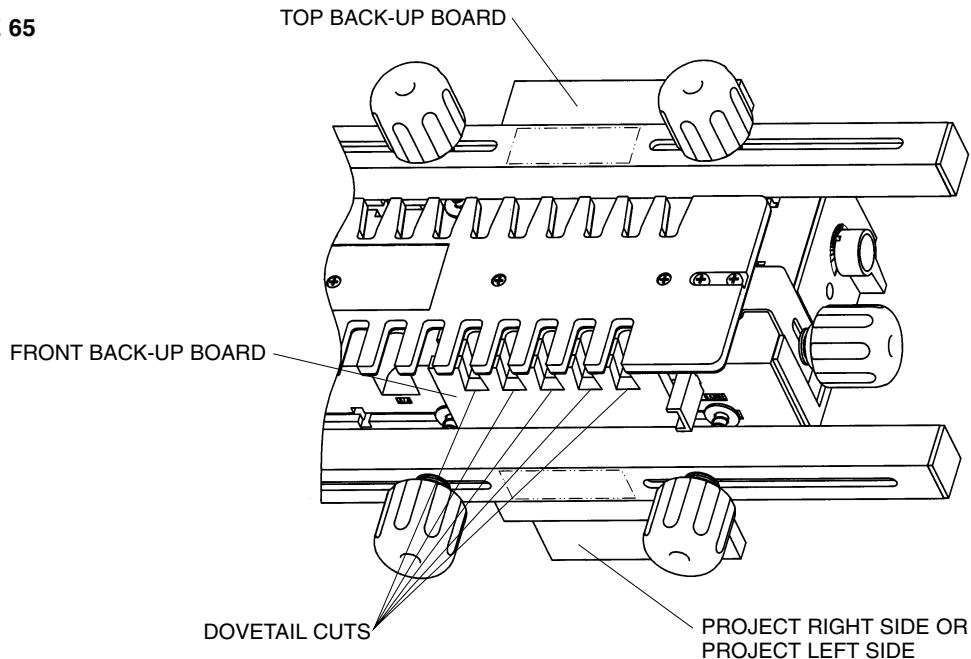
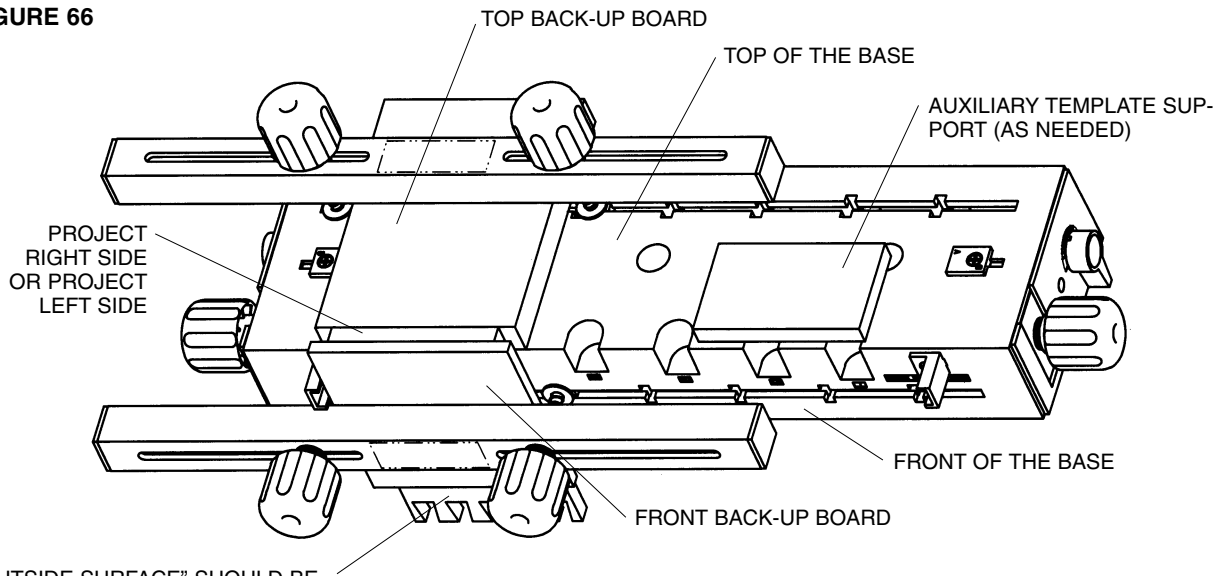

FIGURE 66



“OUTSIDE SURFACE” SHOULD BE VISIBLE ON THIS SURFACE BEFORE POSITIONING THE FRONT BACK-UP BOARD

CAUTION NEVER LIFT THE ROUTER UPWARDS WHEN THE ROUTER IS ON AND THE ROUTER BIT ROTATING OR WHEN THE GUIDE BUSHING IS NEAR TO OR TOUCHING THE TEMPLATE. THIS CAN CAUSE DAMAGE TO THE DOVETAIL JIG; OR LOSS OF CONTROL OF THE ROUTER WHICH CAN RESULT IN SERIOUS BODILY INJURY.

- 19. After the cut has been made, the workpieces should look like those illustrated in Figure 67.
- 20. Remove the workpiece and back-up boards from the Dovetail Jig.
- 21. The back-up boards can be reused if the cut portions of boards are cut off. AFTER BEING REUSED UNTIL THEY NO LONGER SERVE THEIR INTENDED FUNCTION, NEW BACK-UP BOARDS MUST BE MADE.
- 22. TO CUT CORNER #3 OF THE PROJECT LEFT SIDE, position the top back-up board on top of the base so that it lines up with the front of the base and abuts the right top stop block as shown in Figure 63.
- 23. Continue as Steps 6 through 23.
- 24. TO CUT CORNER #2 OF THE PROJECT RIGHT SIDE, position the top back-up board on top of the base so that it lines up with the front of the base and abuts the left top stop block as shown above in Figure 66.
- 25. Lightly clamp the back-up board in place.
- 26. Position the project side against the front of the base so that the top surface abuts the left front stop block. The use of a front back-up board at this step is also recommended. It is positioned between the project side and the clamping bar as shown in Figure 67. The front back-up board is described in Step 6 on page 40.
- 27. Continue as in Steps 8 through 19 above.
- 28. After the cuts have been made, the workpieces should look like those illustrated in Figure 61.
- 29. Remove the workpiece and the back-up boards from the Dovetail Jig.

NOTE: THE BACK-UP BOARDS ARE REUSABLE.

- 30. TO CUT CORNER #4 OF THE PROJECT LEFT SIDE, position the top back-up board on top of the base so that it lines up with the front of the base and abuts the left top stop block as shown in Figure 66.
- 31. Continue as Steps 27 through 32 above.
- 32. At this stage the project sides should look like those illustrated in Figure 61.

FIGURE 67

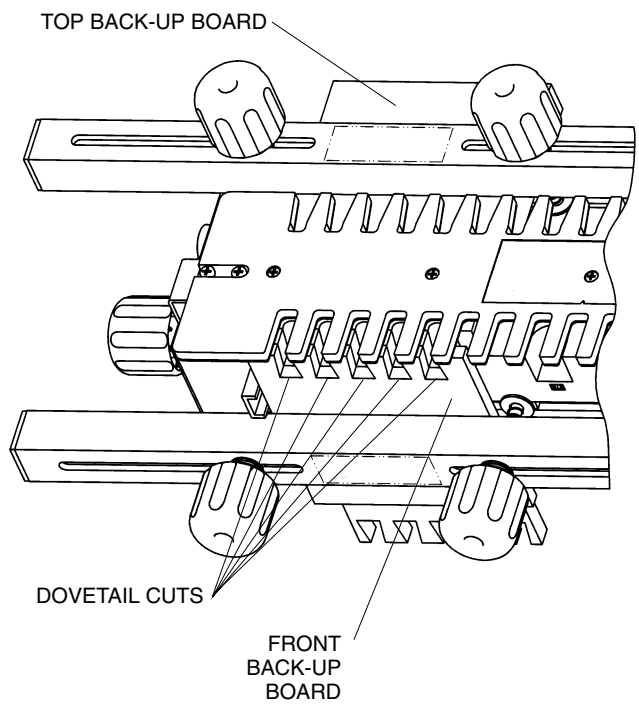

THE FOLLOWING DESCRIBES THE PROCEDURE TO BE FOLLOWED FOR CUTTING THE PROJECT FRONT AND BACK

NOTE: Any joint fit adjustments that may be required can only be made when cutting the project front and back pieces. That is, adjustments are made to project front and back pieces ONLY, not to the side pieces.

1. Assemble the .40" guide bushing to the router baseplate, as described in a previous section. This is the smaller of the two guide bushings furnished with this product.
2. Install Vermont American #22437 or Magna #M91016 straight router bit, to the router as described in your Router Owners Manual. Shank engagement should be a minimum of 3/4".

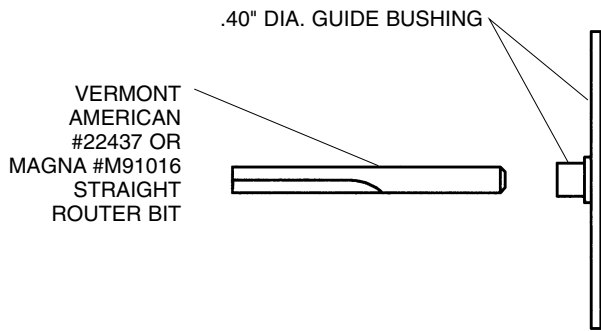

CAUTION MAKE SURE THAT THE ROUTER BIT IS ALIGNED WITH OR CENTERED IN THE HOLE IN THE GUIDE BUSHING. TO DO THIS, LOOSEN SCREWS HOLDING BASE PLATE OR ADAPTER PLATE TO ROUTER, CENTER GUIDE BUSHING HOLE WITH RESPECT TO ROUTER BIT AND RETIGHTEN SCREWS SECURELY.

CAUTION WHEN SETTING THE DEPTH OF CUT, MAKE ABSOLUTELY SURE THAT THE COLLET NUT DOES NOT CONTACT (TOUCH) THE GUIDE BUSHING. THIS CAN CAUSE THE GUIDE BUSHING TO HEAT UP EXCESSIVELY DURING CUTTING WHICH CAN

CAUSE DAMAGE TO THE TEMPLATE. TO CORRECT THIS SITUATION OR PREVENT IT FROM OCCURRING, REPOSITION THE ROUTER BIT IN THE ROUTER

3. Adjust the depth of cut. The depth of cut for an OPEN DOVETAIL JOINT is equal to the thickness of the mating part. That is:

FOR **CORNER #1** OF THE PROJECT **FRONT**, THE DEPTH OF CUT IS EQUAL TO THE THICKNESS OF THE PROJECT **RIGHT** SIDE.

FOR **CORNER #4** OF THE PROJECT **FRONT**, THE DEPTH OF CUT IS EQUAL TO THE THICKNESS OF THE PROJECT **LEFT** SIDE.

FOR **CORNER #2** OF THE PROJECT **BACK**, THE DEPTH OF CUT IS EQUAL TO THE THICKNESS OF THE PROJECT **RIGHT** SIDE.

FOR **CORNER #3** OF THE PROJECT **BACK**, THE DEPTH OF CUT IS EQUAL TO THE THICKNESS OF THE PROJECT **LEFT** SIDE.

Use the depth gauge on the base of the Dovetail Jig, as described in a previous section, as a starting point

4. At this point it will be necessary for you to make a top back-up board. The reasons for the top back-up board are to minimize splintering, provide support for the template and prevent damage to the Dovetail Jig. The top back-up board is a scrap piece of wood having the following dimensions:

LENGTH: 6" to 8", sufficient length so that it can be clamped by the top clamping bar and be used more than once;

WIDTH: 2" wider than the width of the project front (or back)

THICKNESS: 1/8" to 1/4" thicker than the thickness of the project front (or back); **THIS IS TO PREVENT ACCIDENTALLY CUTTING INTO THE DOVETAIL JIG.**

This can also be accomplished by using more than one piece of scrap as long as the resultant length, width, and thickness are as described.

5. TO CUT CORNER #1 OF THE PROJECT FRONT, position the top back-up board on top of the base so that it lines up with the front of the base and abuts the left top stop block as shown in Figure 68.

FIGURE 68

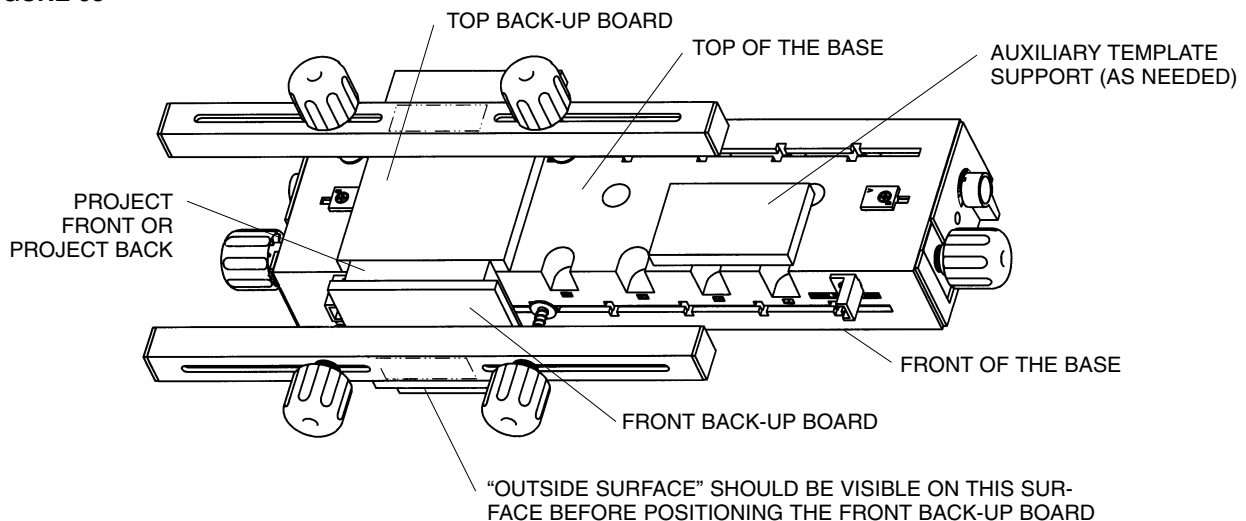
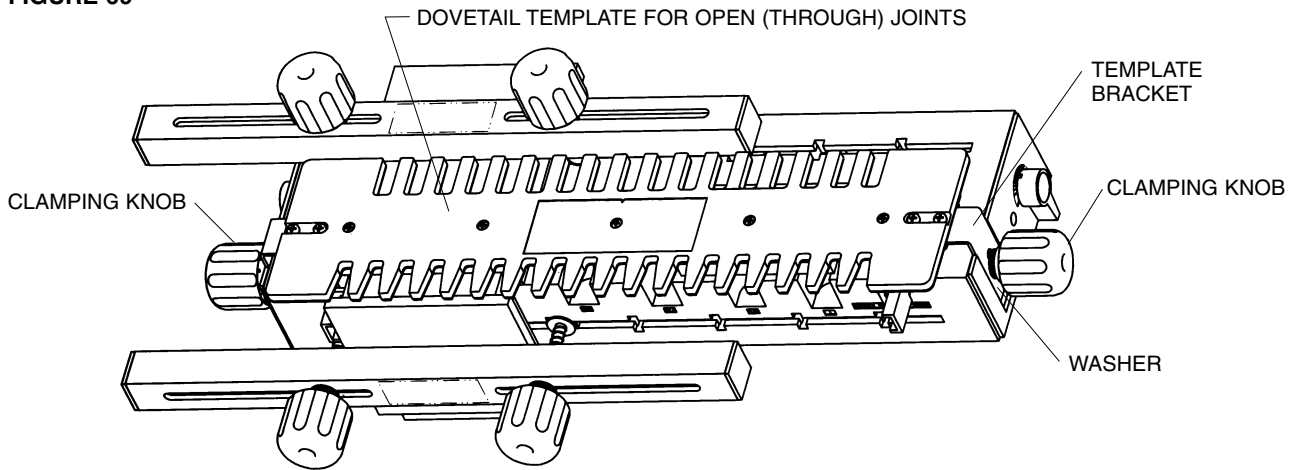

FIGURE 69



6. Lightly clamp the back-up board in place.
7. Position the project front (or back) against the front of the base so that the top surface abuts the left front stop block. The use of a front back-up board at this step is also recommended. It is positioned between the project front (or back) and the clamping bar as shown in Figure 68. The front back-up board should have the following approximate dimensions:

LENGTH: 6" to 8", sufficient length so that it can clamped by the front clamping bar and be used more than once;

WIDTH: 1" to 2" wider than the width of the front (or back);

THICKNESS: 1/4" to 1/2".

THE OUTSIDE OF THE PROJECT FRONT (OR BACK) FACES AWAY FROM THE FRONT OF THE BASE.

The words "OUTSIDE SURFACE" marked in (d) in the Section, GENERAL PREPARATIONS, should have been visible before the front back-up board was put in place

8. Line up the workpieces so that the end of the project front (or back) and back-up boards line up as shown in Figure 68 .

9. Securely clamp the project front(or back) and front back-up board to the front of the base.

10. Securely clamp the top back-up board to the top of the base.

11. Make sure that the parts remain lined up.

12. Assemble the DOVETAIL TEMPLATE FOR OPEN (THROUGH) JOINTS to the Dovetail Jig so that THE TEMPLATE BRACKETS FIT BETWEEN THE WASHERS AND THE TEMPLATE SUPPORTS as shown above in Figure 69; it will be necessary to loosen the clamping knobs at the ends of the base to do this.

13. Make sure that the template is oriented as shown in Figure 69.

14. Make sure that the template is flush and parallel with the workpieces clamped to base. For narrow project fronts (or backs), the use of an auxiliary support for the template is recommended. Its purpose is to aid in supporting the router while cutting. It can be made from a piece of scrap wood; but its thickness must be the same as the top back-up board. (Refer to Figure 68.)

15. Clamp the template in place by tightening the clamping knobs.

- CAUTION** BEFORE MAKING ANY CUTS MAKE SURE THAT THE BIT WILL NOT CUT INTO THE BASE OR ANY OTHER COMPONENT OF THE DOVETAIL JIG. THIS CAN CAUSE DAMAGE TO THE DOVETAIL JIG.
16. TURN THE ROUTER ON.
 17. Cut the dovetail by moving the router from LEFT TO RIGHT, with the guide bushing following the template. DO NOT FORCE ANYTHING; MOVE THE ROUTER IN SLOW AND SMOOTH FASHION.
 18. To ensure a smooth and uniform joint, retrace the previous cut by moving the router from RIGHT TO LEFT with the guide bushing again following the template.
 19. MAKE SURE THAT ALL OF THE MATERIAL IS CUT AWAY; FREE ROUTING MAY BE REQUIRED TO ACCOMPLISH THIS. **EXTRA CARE IS REQUIRED IN CONTROLLING THE ROUTER MOVEMENT WHILE DOING FREE ROUTING.** (Refer to Figure 70).

FIGURE 70

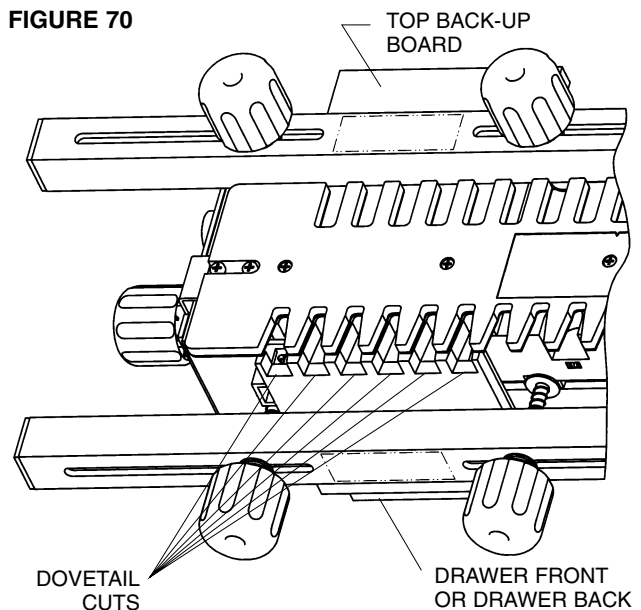



NEVER LIFT THE ROUTER UPWARDS WHEN THE ROUTER IS ON AND THE ROUTER BIT ROTATING OR WHEN THE GUIDE BUSHING IS NEAR TO OR TOUCHING THE TEMPLATE.

20. After the cut has been made, the project back and front should look like those illustrated in Figure 61.
21. Remove the workpiece and back-up boards from the Dovetail Jig.
22. The back-up boards can be reused if the cut portions of boards are cut off. AFTER BEING REUSED UNTIL THEY NO LONGER SERVE THEIR INTENDED FUNCTION, NEW BACK-UP BOARDS MUST BE MADE.
23. TO CUT CORNER #3 OF THE PROJECT BACK, position the top back-up board on top of the base so that it lines up with the front of the base and abuts the left top stop block as shown in Figure 68.
24. Continue as Steps 6 through 24.
25. TO CUT CORNER #4 OF THE PROJECT FRONT, position the top back-up board on top of the base so that it lines up with the front of the base and abuts the right top stop block as shown in Figure 71.
26. Lightly clamp the back-up board in place.
27. Position the project front (or back) against the front of

the base so that the top surface abuts the right front stop block. **The use of a front back-up board at this step is also recommended.** It is positioned between the drawer front (or back) and the clamping bar as shown in Figure 71. The front back-up board is described in Step 7 above.

28. Continue as in Steps 8 through 20 above.
 29. After the cuts have made, the workpieces should look like those illustrated in Figure 61.
 30. Remove the workpiece and the back-up boards from the Dovetail Jig.
- NOTE: THE BACK-UP BOARDS ARE REUSABLE.**
31. TO CUT CORNER #2 OF THE PROJECT BACK, position the top back-up board on top of the base so that it lines up with the front of the base and abuts the right top stop block as shown in Figure 71.
 32. Continue as Steps 28 through 32 above.
 33. The finished project front, back, and sides should look like those illustrated in Figure 61.
 34. Check how the workpieces fit together. Some adjustments may be necessary. Refer to the section, TROUBLESHOOTING.
- Your project is now ready to be glued together.
 - Remove the pencil markings by light sanding or with a soft eraser after the parts have been glued together.

FIGURE 71

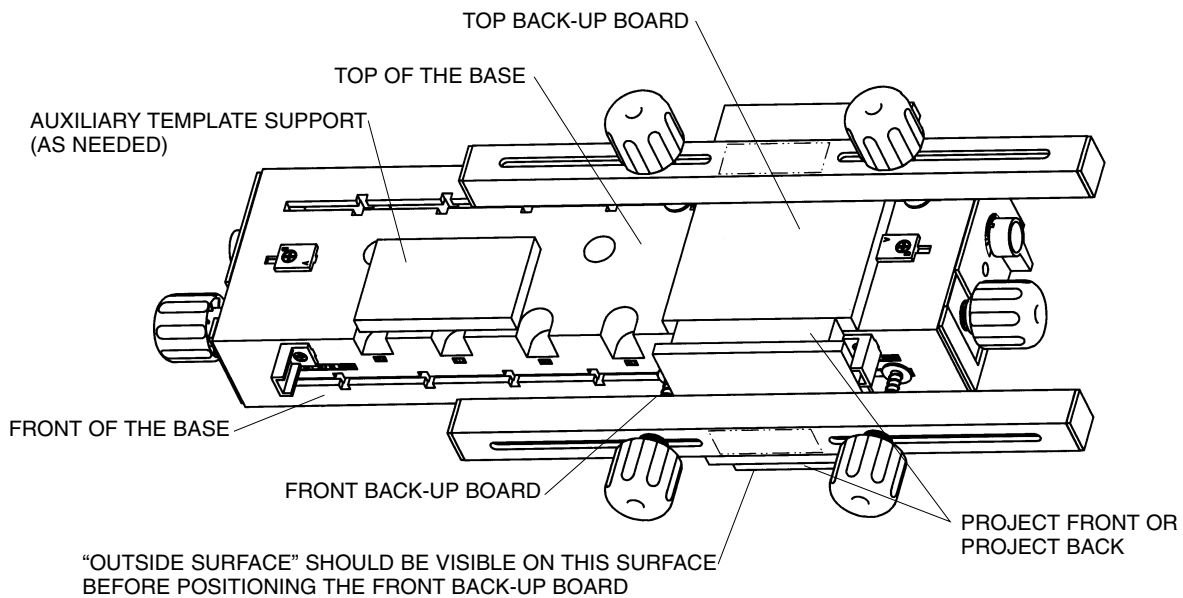

TROUBLESHOOTING

- **If the joint is too loose:** This adjustment can only be made when cutting either the front or the back (tail pieces). Loosen the clamping knobs holding the template brackets and move the template **OUTWARD** by turning the cam handles. Continue adjusting until desired joint fit is attained. Retighten the clamping knobs.

- **If the joint is too tight:** This adjustment too can only be made when cutting either the front or the back (tail pieces). Loosen the clamping knobs holding the template brackets and move the template **INWARD** by turning the cam handles. Continue adjusting until desired joint fit is attained. Retighten the clamping knobs.

- **If the joint is too shallow:** Refer to Figure 72. **INCREASE** the depth of cut of the router bit. This adjustment can be made when cutting the front, the back, (tail pieces) and the sides (pin pieces).

- **If the joint is too deep:** Refer to Figure 73. **DECREASE** the depth of cut of the router bit. This adjustment too can be made when cutting the front, the back, (tail pieces) and the sides (pin pieces).

- **If the joint is not uniformly spaced from top surface of drawer:** Refer to Figure 74. (See the Section "ALIGNMENT OF THE TEMPLATES".) With the template clamped to the base, loosen the four screws securing the template to the template brackets, and move the template slightly to the left. Tighten the four screws and make a trial cut. If moving the template to the left did not correct the condition, but made it worse, loosen the screws and move the template to the right a small amount. Make sure the template remains parallel to the front of the dovetail base. Tighten the four screws and make a trial cut. Continue moving the template to the right until the condition is completely corrected. **PROPER ALIGNMENT OF THE TEMPLATES TO THE TEMPLATE BRACKETS IS CRITICAL FOR JOINT UNIFORMITY. ONCE THIS IS ACCOMPLISHED CORRECTLY, IT SHOULD NOT NEED ADJUSTMENTS AGAIN. MAKE SURE TO SECURELY TIGHTEN THE FOUR SCREWS. AFTER THE TEMPLATES HAVE BEEN CORRECTLY REALIGNED, THEY SHOULD REQUIRE NO FURTHER ADJUSTMENTS IF THEY ARE HANDLED WITH CARE.**

FIGURE 72 – JOINT IS TOO SHALLOW

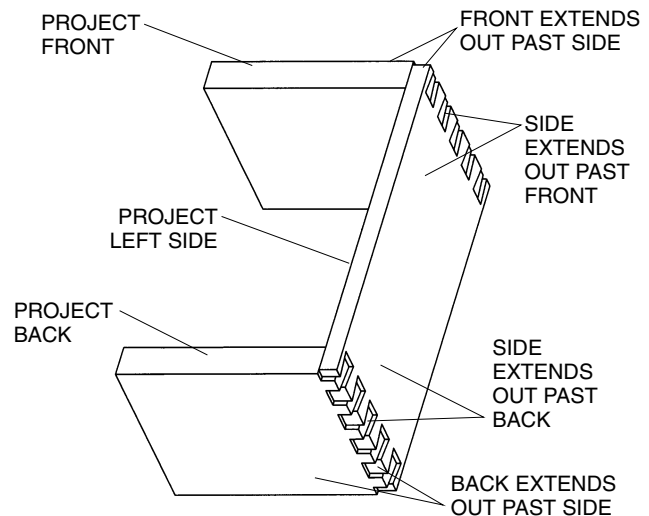

FIGURE 73 – JOINT IS TOO DEEP

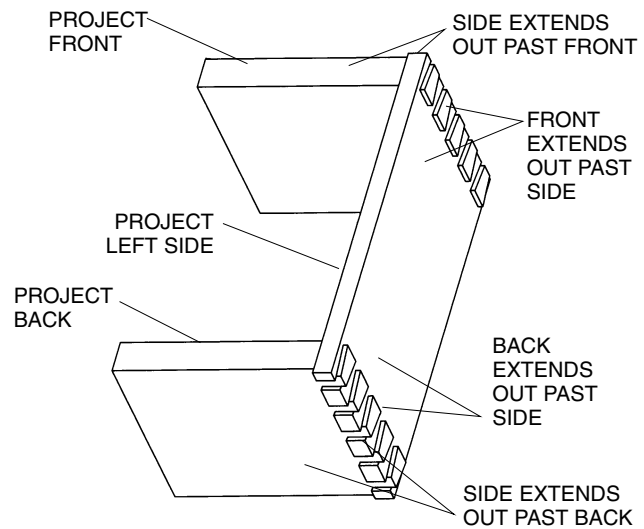
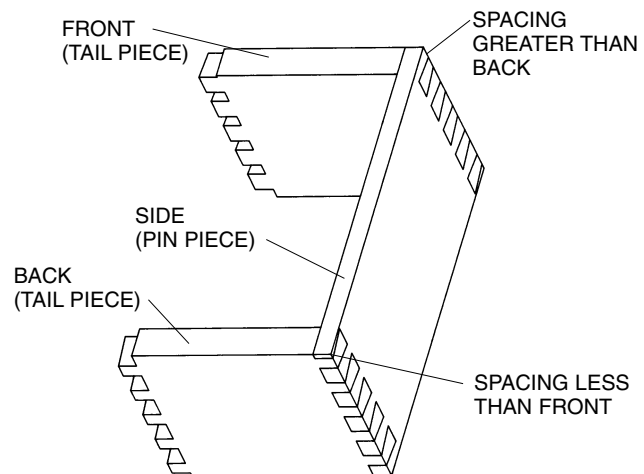

FIGURE 74 – JOINT SPACING IS NOT EQUAL



PARTS LIST

PARTS LIST FOR VERMONT AMERICAN INDUSTRIAL DOVETAIL JIG

MODEL NO. 23461

KEY	PART NO.	DESCRIPTION	QTY	KEY	PART NO.	DESCRIPTION	QTY
1	29LD-879-1	Deluxe Dovetail Base	1	24	29L-469-13	#10-32 X 5/8" Ig. Panhead Machine Screw	4
2	29LD-880-1	Dovetail Template (Blind Joint)	1	25	29L-469-14	#10-32 X 3/8" Ig. Panhead Machine Screw	8
3	29LD-881-1	Dovetail Template (Open Joint)	1	26	29L-469-15	#8-36 X 3/16" Ig. Panhead Machine Screw	10
4	29LD-882	Template Support (Right Side)	1	27	29LD-841-2	#10-32 X 5/8" Ig. Flat Head Machine Screw	2
5	29LD-883	Template Support (Left Side)	1	28	29LD-841-3	#10-32 X 7/8" Ig. Flat Head Machine Screw	2
6	29LD-884-1	Cam Handle	2	29	29LD-841-4	#10-32 X 3/8" Ig. Flat Head Machine Screw	3
7	29LD-885-1	Front Stop Block	2	30	29L-684-6	#10-16 X 1/2" Ig. Panhead Tapping Screw	1
8	29LD-886-1	Top Stop Block	2	31	29L-684-7	#10-16 X 1" Ig. Panhead Tapping Screw	3
9	29LD-887	Clamping Bar End Cap	4	32	29A-310-15	5/16-18 X 4-1/2" Ig. RD HD SQ Neck Bolt	2
10	29LD-888-1	Retainer	1	33	29A-310-16	5/16-18 X 3-1/2" Ig. RD HD SQ Neck Bolt	2
11	29LD-889-1	Bolt Support	4	34	29A-310-17	5/16-18 X 2" Ig. RD HD SQ Neck Bolt	2
12	29LD-890-1	Clamping Knob	6	35	29A-242-12	#10-32 Hex Machine Screw Nut	4
13	29LD-891	Clamping Bar	2	36	29A-242-13	5/16-18 Hex Machine Screw Nut	2
14	29LD-892	Pivot Shaft	1	37	29A-306-20	13/64" ID X 15/32" OD X 3/64" Thick Washer	13
15	29LD-895	Template Bracket	4				
16	29LD-896	Template Stiffener	2	38	29A-306-40	11/32" ID X 7/8" OD X 1/16" Thick Washer	8
17	29LD-899	Guide Bushing Assembly (.4" Dia.)	1	39	29LD-930	11/32" ID X 7/8" OD Thin Nylon Washer	4
18	29LD-900	Guide Bushing Assembly (1/2" Dia.)	1	40	29LD-969	5/16" ID X 7/8" OD Thick Nylon Washer	4
19	29LD-901	Compression Spring	4	41	29LCN-1005	Spring Retainer	4
20	45A-414	Product Label (Clamping Bar)	1	42	29A-368-1	#8 Countersunk Bushing	4
21	45A-416	Label (Template-Blind)	1	43	29A-368-2	#10 Countersunk Bushing	4
22	45A-417	Label (Template-Open)	1	44	29GD-375	Router Adapter Plate	1
23	45A-415	Warning Label (Clamping Bar)	1	45	VA #25500	1/2" VA Dovetail Router Bit	1
				--	45LCN-72	Instruction Manual	1

Key No.'s 29, 42, 43, 44, and 45 along with four of Key No. 37 are furnished loose and unassembled.

BASE ASSEMBLY

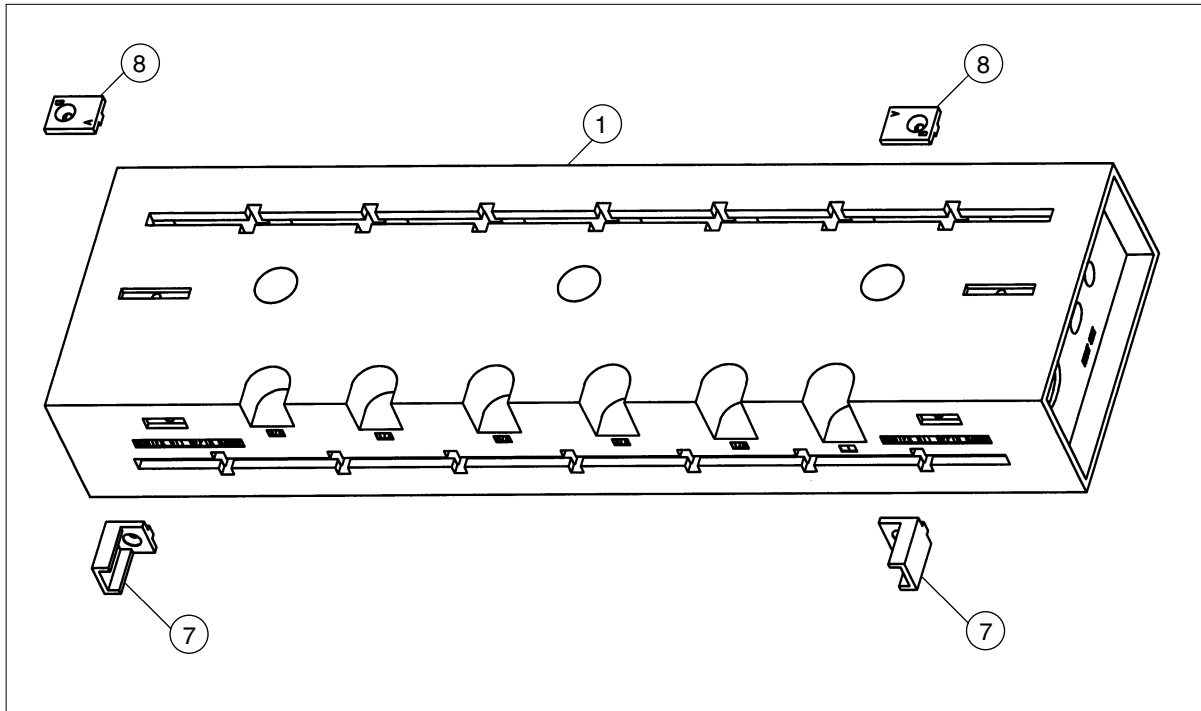

TEMPLATE SUPPORT ASSEMBLY

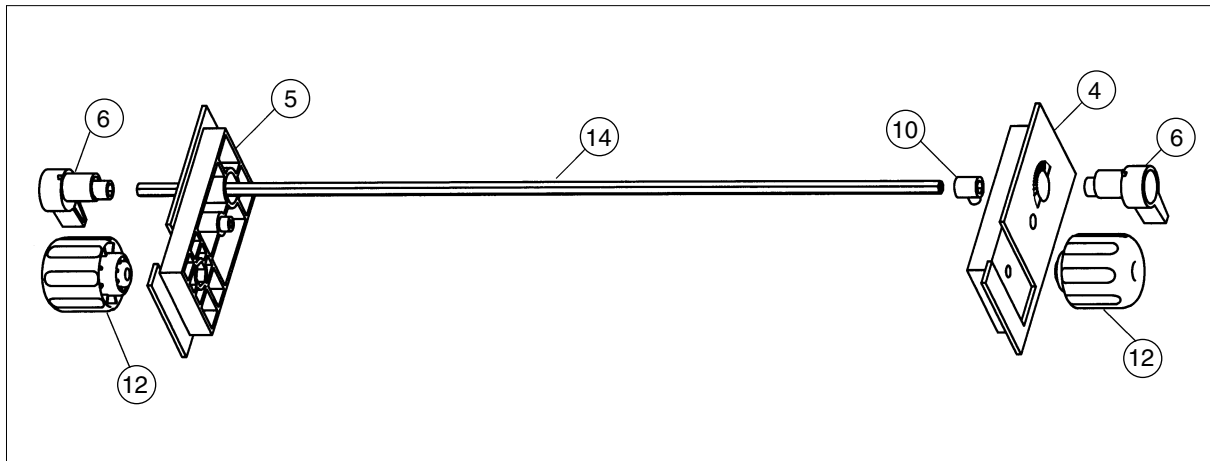

CLAMPING ASSEMBLY

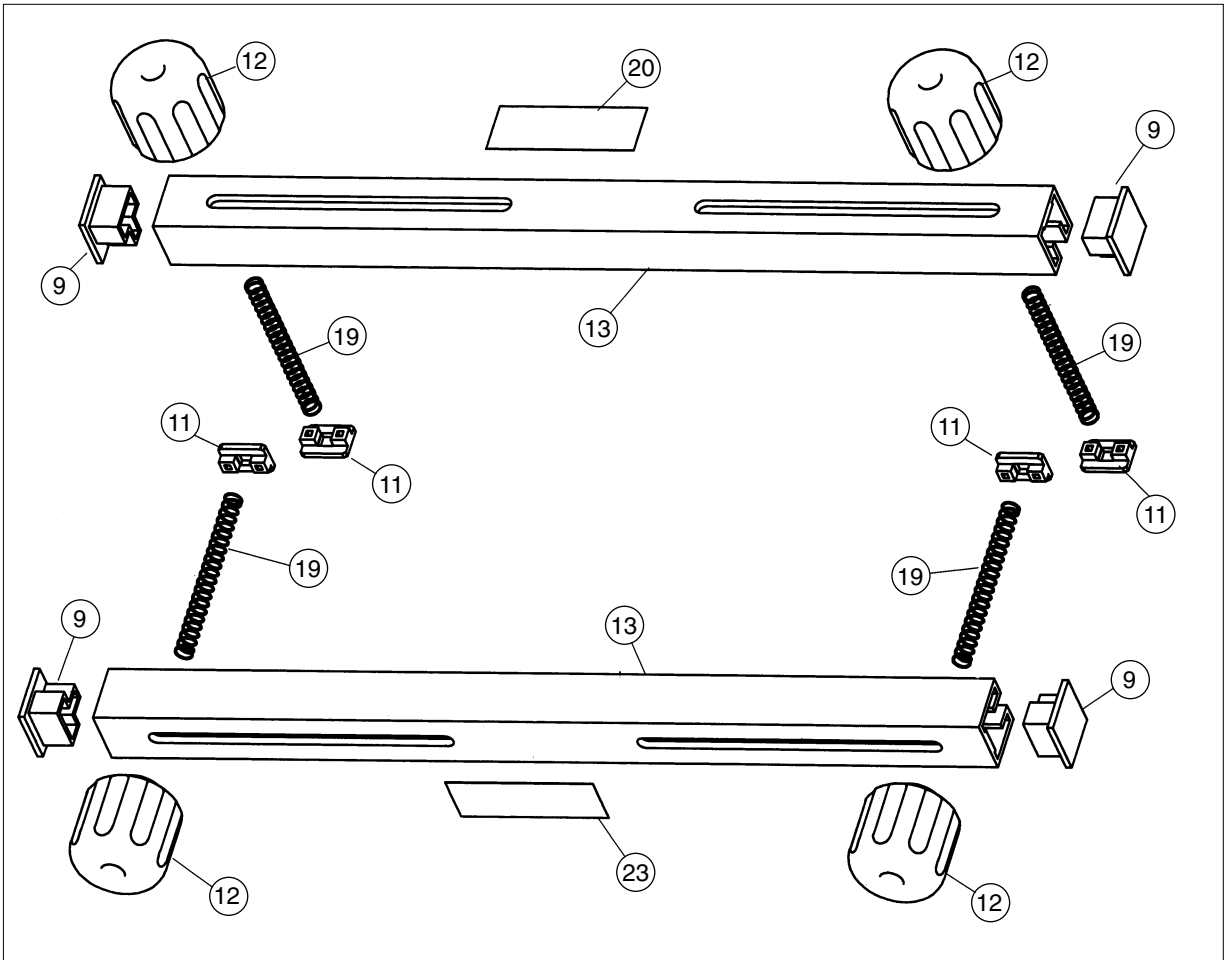

ROUTER ADAPTER PLATE

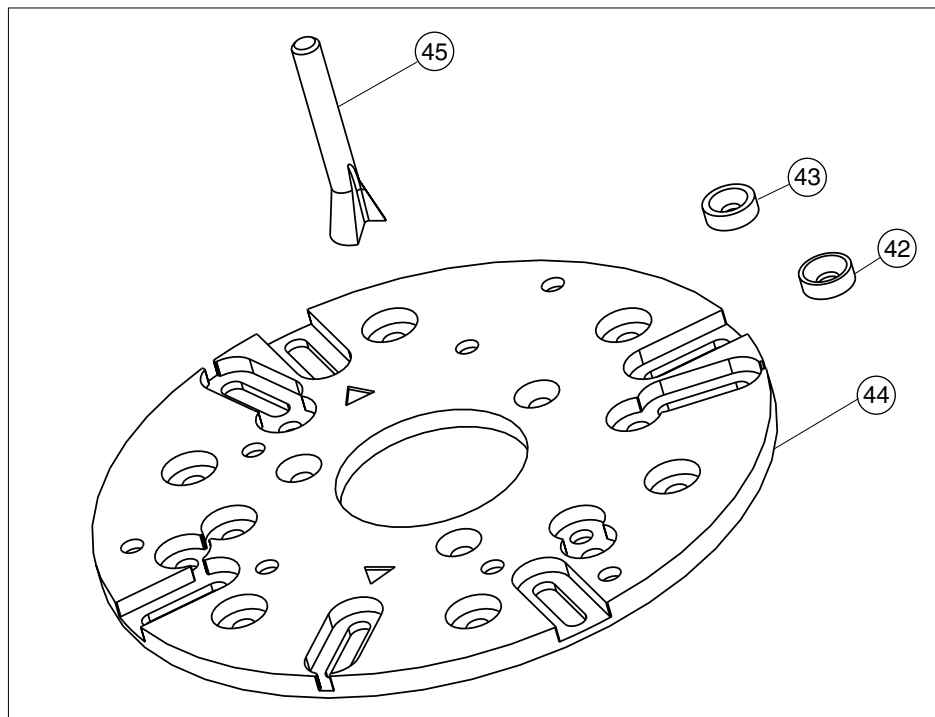

TEMPLATES

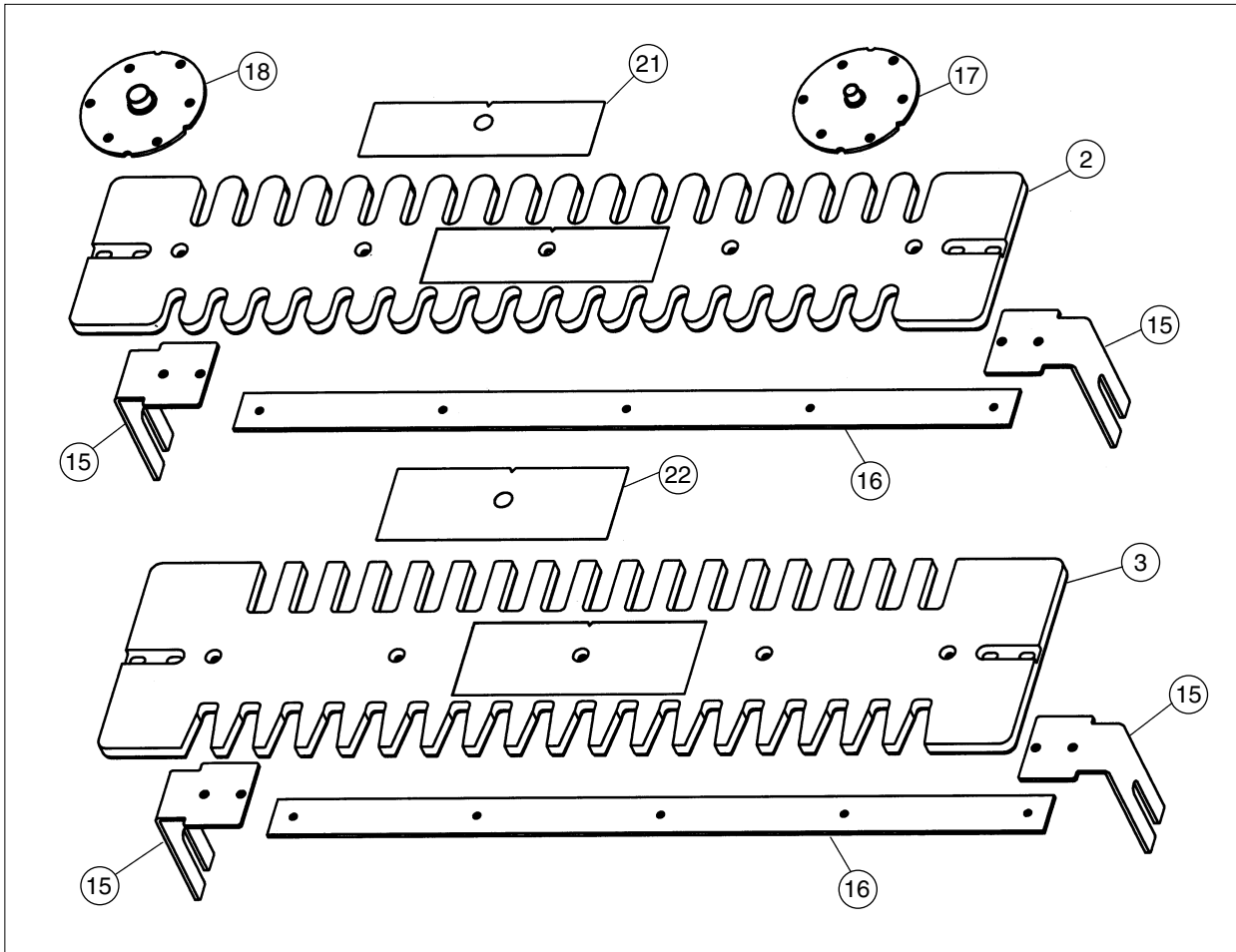

FASTENERS

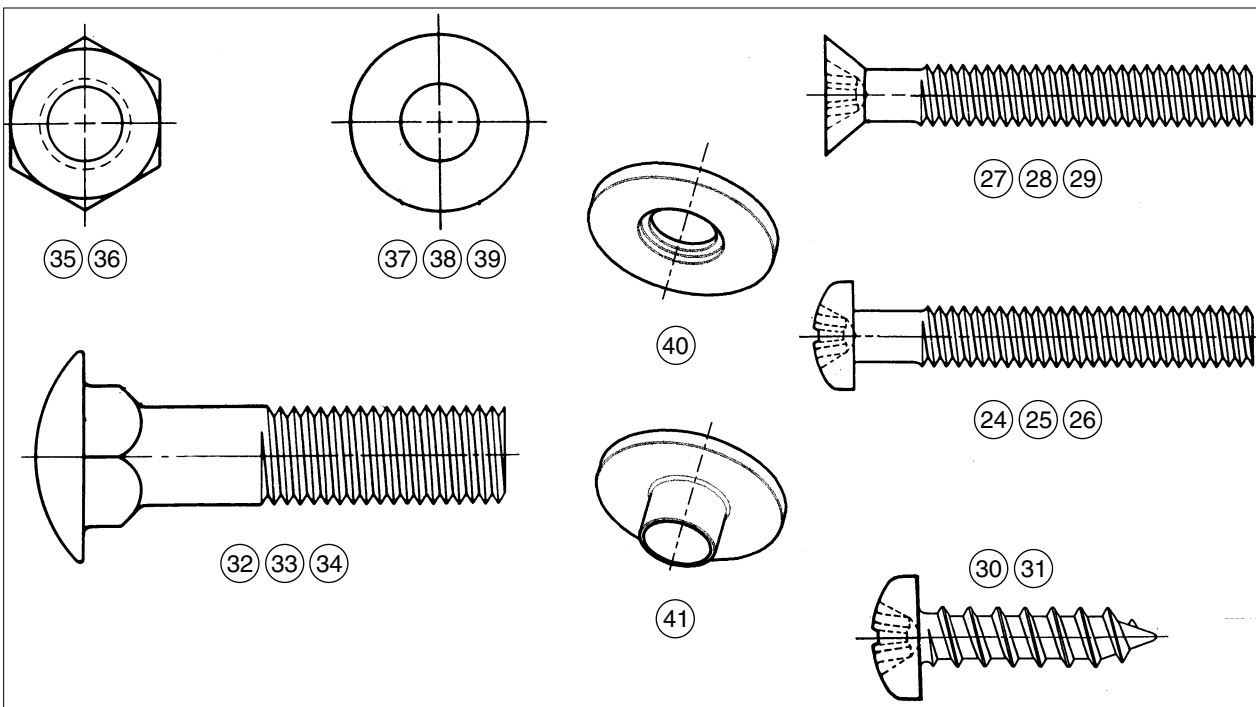

NOTES

To obtain a copy of this Manual in French, call the following toll-free number 1-800-742-3869.

To obtain a copy of this Manual in Spanish, call the following toll-free number 1-800-742-3869.

When corresponding, always give the following information as shown in the list.

1. The PART NUMBER
2. The PART DESCRIPTION
3. The MODEL NUMBER: 23461
4. The ITEM NAME – INDUSTRIAL DOVETAIL JIG

Printed in U.S.A.
08/99
Manual No. 45LCN-72
